



SERVICE GUIDE

Avalon CTS

Cordless Fetal Transducer System

M2720A

FETAL MONITORING

PHILIPS

Printed in Germany 10/04



Part Number M2720-9000C
4512 610 04681



Avalon CTS

Cordless Fetal Transducer System

M2720A

SERVICE GUIDE



M2720-9000C

October 2004

Printed in Germany

PHILIPS



Contents

1 General Information	1
Who Should Read This Guide	1
What to Do Next	1
Repair Strategy	2
Pre-Installation Considerations	2
When is the Avalon CTS Customer Installable?	2
When are Special Configurations Needed?	3
Warnings, Cautions and Important Information	3
Symbols on the System	3
Patient Safety	4
Protective Earth	5
Environment	5
General Description	5
Mounting Solutions	6
Applying the Velcro Fixing Tape	7
Antenna Extension Mounting Kit	8
Mounting on Philips Carts	8
Mounting on Wooden Carts and Other Flat Surfaces	9
Considerations for Choice of Configuration	9
Frequency Bands	9
Standard Delivery Configuration	10
When is a Different Configuration Needed?	10
When the Area of Reach is Not Sufficient	10
When the Standard Configuration is Unsuitable	10
Japanese Systems	10
Multi-Region Base Station	11
Frequency Planning	11
Setting Expectations	11
Antenna System Guidelines	12
Before You Install an Antenna System	12
Specifications	13
Mixed Telemetry Devices on the Same M2600A Antenna System	13
2 Theory of Operation	15
Receiver Board	16
Human Interface Board	16
Power Supply	16
Slot Control and Monitor Interface Board Hardware	16

Transducer Hardware Overview	17
Functional Description of the RF/CPU Hardware	17
Base Station Communication	18
Power Supply and Battery Charger	18
Modulator	18
RF Transmitter	18
Toco Frontend Hardware	18
Ultrasound Frontend Hardware	18
ECG Frontend Hardware	18
3 System Interfaces	21
<hr/>	
Fetal Monitor Interface	21
Service Interface	22
Compatible Fetal Monitors	23
4 Disassembly/Reassembly	25
<hr/>	
Introduction	25
Removing the Top Cover Assembly	26
Replacing the Top Cover Assembly	27
Changing Fuses	28
Changing the Power Supply/Metal Chassis Assembly	31
5 Spare Parts	39
<hr/>	
Exchange Parts	39
Non-Exchange Parts	40
Supplies and Accessories	40
Antenna and Base Station Part Numbers	41
6 Preventive Maintenance and Safety	43
<hr/>	
Care and Cleaning	43
Recommended Frequency of Testing	43
Performance Assurance Tests	44
Self Test	44
Parameter Test	44
Testing Alarms	45
Safety Tests	45
Safety Test Procedures	46
When to Perform Safety Tests	46
How to Carry Out the Test Blocks	47
Description of Applicable Safety Tests	48
S(1): Protective Earth Test	48
S(2): Enclosure Leakage Current Test	
- Normal Condition (NC)	48
S(3): Enclosure Leakage Current Test	
- Single Fault Condition (SFC) Open Supply	49

S(4): Enclosure Leakage Current	
- SFC Open Earth (Ground)	49
Instrument Safety Test	50
System Test	50
What is a Medical Electrical System?	50
General Requirements for a System	50
System Example	51
Regular Preventive Maintenance	51
Mechanical Inspection	51
Visual Check	52
Toco Ventilation/Belt Button	52
Testing the Ventilation Membrane	52
Battery Check	53
Starting the Battery Check	53
Stopping the Battery Test	54
Stages of the Battery Check	54
Reading Battery Check Data Using the Service Support Tool	55
Battery Exchange	55
7 Troubleshooting	57
<hr/>	
System is Completely Inoperative	57
System Reset	57
Common Problems	58
Troubleshooting a Cordless System: an Overview	59
Checking Contacts	60
Checking the Fetal Monitor	60
RF Problems	60
Carrier to Noise Ratio	60
Gathering Data	61
Observe System Performance	61
Question the User	61
Area of Reach	62
Range Definition	62
Using the Base Station	62
Using the Service Support Tool	63
RF Interference	63
One-Channel or Narrowband Interference	63
Broadband Interference	64
Guidelines for Channel/Frequency Configuration	64
Scanning the Available Frequency Range	64
Excluding Frequencies	65
Base Station with Fixed Frequency	65
Transducers with Fixed Frequency	66
Transducers for Japan	66

Multi-Region Base Station	66
Delivery Status	66
Installation	66
Testing Transducers	67
Ultrasound Transducer Electrical Check	67
TOCO Transducer Electrical Check	68
ECG Transducer Electrical Check	69
In DECG Mode	69
In MECG Mode	70
Troubleshooting the Top Cover	71
Function Buttons	71
Display/Window	72
LEDs	72
Magnets	72
Factory Information Code Log	72
8 Changing Settings	73
<hr/>	
Configuration Settings	73
Function Settings	74
Bed Label Appearance	74
Enabling/Disabling Fixed Frequency	74
Selecting the Channel Frequency Spacing	75
Action Settings	77
Displaying the Software Revision	77
Clearing the Factory Information Code (FIC) Log	77
Starting the Battery Check	78
9 Upgrades	79
<hr/>	
10 Specifications	81
<hr/>	
General	81
Base Station	81
Transducers	82
Frequency Bands	83
Frontends	83
Cables	84
Electromagnetic Compatibility (EMC) Specifications	85
Emissions and Immunity	85
Electromagnetic Immunity	85
Finding Recommended Separation Distances	86
Recommended Separation Distances from Portable and Mobile RF Communication Equipment	88

A Removing and Replacing the Transducer Battery	89
B Removing and Replacing the Transducer Belt Button	91
C Avalon CTS Frequency Table	93



General Information

This guide tells you how to service and repair the base station (M2720A) and transducers (M2725A, M2726A, and M2727A) of the Avalon CTS Cordless Fetal Transducer System. It describes the system hardware and software, tells you how to diagnose operating and servicing problems, and how to test the system.

As this system is intended to be installed by the customer, refer to the *Instructions for Use* for details of how to install the system. See also “Pre-Installation Considerations” on page 2.

The *Avalon CTS Cordless Fetal Monitoring System Service Guide* supplements the maintenance and troubleshooting procedures, carried out by the operator, that are described in the *Instructions for Use*. Refer to the *Instructions for Use* for maintenance and troubleshooting procedures that may be performed during normal operation.

Only qualified service personnel should attempt to install the system, disassemble the base station, remove or replace any internal assemblies, or replace the transducer batteries or belt buttons.

Who Should Read This Guide

This guide is for any qualified technical personnel servicing and repairing the Avalon CTS Cordless Fetal Transducer System.

You must:

- understand English
- be familiar with standard medical equipment installation procedures
- be familiar with current conventional technical terms as used throughout this guide

What to Do Next

Familiarize yourself with the contents of this guide and the *Instructions for Use* before attempting to service or repair the system.

Repair Strategy

The Service Support Tool software helps you to determine whether a fault is a hardware, software or RF-related problem. Any maintenance and repair procedures beyond the level covered in the *Instructions for Use* are limited to:

- unit exchange for
 - the base station
 - the transducers
- replacement of
 - the top cover assembly, including human interface board
 - the power supply, including metal chassis
 - two fuses in the power supply
 - the transducer battery
 - the transducer ventilation knob

Repair or replacement of individual components on the boards is not supported, and should never be attempted.

For any problem related to connecting the base station to an antenna system, refer to the M2600A Telemetry System's *Service Training and Reference Guide*.

For tests that you are required to perform after repairs, refer to “When to Perform Safety Tests” on page 38.

Pre-Installation Considerations

There are a number of factors you need to consider that influence how you install the Avalon CTS.

When is the Avalon CTS Customer Installable?

The Avalon CTS is intended to be customer installable under the following conditions:

- The system in its standard configuration is an “out-of-the-box”, standalone system, delivered with automatic frequency allocation, and is intended to be used with the standard antenna supplied, giving a line-of-sight operating range up to 100m/300ft.
- There are less than ten stand-alone systems in the institution.
- Connection to an antenna system is not planned.
- No other telemetry devices are used in the institution that can influence, or be influenced by, the Avalon CTS.
- There are no other sources of RF interference that influence the operation of the Avalon CTS.
- There are no country-specific regulations requiring special configuration.

Installation should be carried out by qualified technical personnel.

If you need to mount the Avalon CTS, or use the antenna extension mounting kit (M1361A Option 1AA), see page 8 for further details.

When are Special Configurations Needed?

If one or more of the conditions above are not met, you need a special configuration of the Avalon CTS (refer also to “Considerations for Choice of Configuration” on page 9). For instance, you may need to:

- Set fixed frequencies when there are other telemetry systems installed in the same institution. (In Japan, local regulations always require the setting of fixed frequencies.) This configuration should be carried out by qualified service personnel, either from the hospital’s biomedical department, or from Philips.
- Connect the Avalon CTS to an antenna system because the standard antenna is not sufficient to cover the area intended for cordless monitoring. Site preparation, antenna system design (including guidelines for mixed telemetry equipment installations), and installation should be carried out by qualified service personnel from Philips.
- There are country-specific regulations requiring special configuration (in Japan, for example), or your country requires a Multi-Region base station.

Warnings, Cautions and Important Information

WARNING A warning alerts you to a potential serious outcome, adverse event or safety hazard. Failure to observe a warning may result in death or serious injury to the user or patient.





CAUTION A caution alerts you to circumstances where special care is necessary for the safe and effective use of the product. Failure to observe a caution may result in minor or moderate personal injury, damage to the product or other property, and possibly in a remote risk of more serious injury.







In this book, graphical symbols (indicators or elements of the base station or transducer displays) depicted in this way indicate that they are blinking.

© Copyright 1995-2004 Koninklijke Philips Electronics N.V. All Rights Reserved.

Symbols on the System

	This attention symbol indicates that you should consult this book and the <i>Instructions for Use</i> , and particularly any warning messages.
	Power-On/Stand-by Switch.
	Power-On/Stand-by Indicator.
	Equipotential Terminal. This symbol identifies terminals that are connected together, bringing various equipment or parts of a system to the same potential. This is not necessarily earth potential. The value of potentials of earth may be indicated adjacent to the symbol.

	Protective Earth Terminal. This symbol identifies the terminal for connection to an external protective earth system.
	Antenna input symbol.
	Service socket symbol.
	This symbol appears on the device adjacent to the CE mark and defines Class 2 radio equipment per Radio and telecommunications Terminal Equipment Directive 1995/5/EC.
IPX1	Ingress Protection code according to IEC 60529. Base station is rated IP X1 (protection against vertical water drops only).
IP68	Ingress Protection code according to IEC 60529. All transducers are rated IP 68 (protection against dust, access to hazardous parts, and the effects of continuous immersion in water to a depth of 0.5 meter for five hours).
	Type CF equipment.

Patient Safety

The Telemetry System should only be used by, or under the direct supervision of, a licensed physician or other health care practitioner who is trained in the use of fetal heart rate monitors and in the interpretation of fetal heart rate traces. US federal law restricts this device to sale by, or on the order of, a physician.

The base station (telemetry receiver) is a Protection Class 1 instrument.

The device complies with the following safety standards:

- EN 60601-1:1990+A1:1993+A2:1995 / IEC 60601-1:1988+ A1:1991+A2:1995
- EN 60601-1-1:2001 / IEC 60601-1-1:2000
- UL2601-1:1997
- CAN/CSA C22.2 No. 601.1-M90
- JIS T 1001-1992
- JIS T 1002-1992
- AS 3200.1.0-1998

The cordless transducers are battery operated devices, applied parts (patient connectors) are Type CF



Protective Earth

WARNING Check each time before use that the system is in perfect working order and the base station is properly grounded.

This equipment is intended for use only within healthcare facilities. It is not suitable for use in domestic establishments and in establishments directly connected to a low voltage power supply network, which supplies buildings used for domestic purposes.

Do not use additional AC mains extension cords or multiple portable socket-outlets. If a multiple portable socket-outlet without a separation transformer is used, the interruption of its protective earthing may result in enclosure leakage currents equal to the sum of the individual earth leakage currents.

To protect hospital personnel and the patient, the cabinet must be grounded. Accordingly, the base station is equipped with a 3-wire power cable which grounds it to the power line ground when plugged into an appropriate 3-wire receptacle. Do not use a 3-wire to 2-wire adapter with the base station. Any interruption of the protective earth grounding will cause a potential shock hazard that could result in serious personal injury.

Whenever it is likely that the protection has been impaired, the base station must be made inoperative and be secured against any unintended operation.

The patient cable must be positioned so that it does not come into contact with any other electrical equipment.

Before operation, make sure that the base station is free from condensation. This can form when equipment is moved from one building to another, and is exposed to moisture and differences in temperature.

Environment

Before operation, make sure that the base station is free from condensation. This can form when equipment is moved from one building to another, and is exposed to moisture and differences in temperature.

Use the system in an environment which is reasonably free from vibration, dust, corrosive or explosive gases, extremes of temperature, humidity, and so forth. It operates within specifications at ambient temperatures between 0°C and +45°C/32°F and +113°F. Ambient temperatures that exceed these limits can affect the accuracy of the system, the transmitter radio frequency transmission, and can damage the components and circuits.

The system can be stored at ambient temperatures between -20°C and +60°C/-4°F and +158°F.

The transducers are watertight to a depth of 0.5 meter/1.64 feet (rated IP 68).

The base station is protected against vertically falling water drops only (rated IP X1 according to IEC 60529).

General Description

Refer to the *Instructions for Use* for operating information for the base station and the transducers. It includes descriptions of the installation and setup of the system and modes of operation.

Mounting Solutions

You can mount the Avalon CTS as follows:

- In a standard cart drawer. The base station with docked transducers fits into Philips Carts CL, CX and CM.

Note: if you mount the base station in a cart or in such a way that the standard antenna cannot be attached directly to the base station, or does not provide sufficient transmission range, use the antenna extension mounting kit (M1361A Option 1AA).

- On top of carts, desks or other flat surfaces using the mounting brackets.
- In a wide variety of situations using the GCX mounting adapter for mounting the base station (order directly from GCX, part number PH-0042-80).
- On top of Series 50 IX/XM/XMO fetal monitors using the mounting brackets.

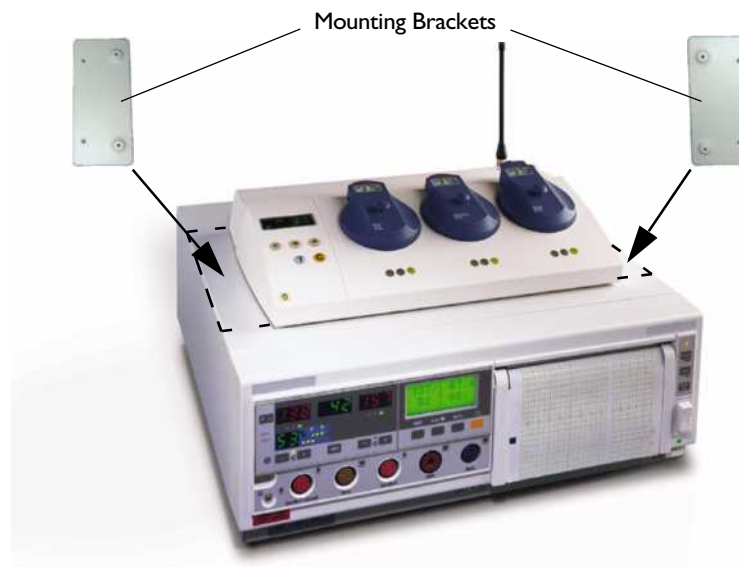

Contact your local Philips representative for additional cart mounting options. Refer also to the fitting instructions that come with the relevant solution.

Applying the Velcro Fixing Tape

Two self-adhesive Velcro fixing tape sets are supplied, each set consisting of two halves.

- 1 Strip off the paper backing on one half of the Velcro set and attach to one side of the underneath of the base station. Repeat for the other side.
- 2 Strip off the paper backing on the other half of the Velcro set and attach to the fixing surface so that the two halves of the Velcro set mate up when the base station is correctly positioned.

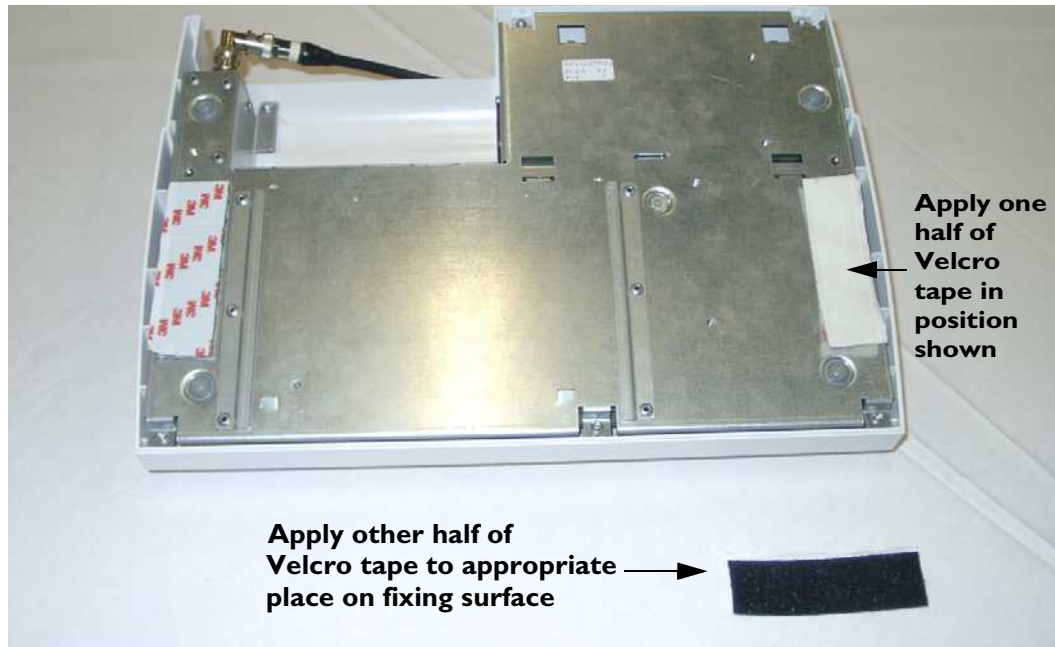

Antenna Extension Mounting Kit

If the base station is installed in a cart or other mounting solution where the standard antenna cannot be attached directly to the base station, or does not provide sufficient transmission range, use the antenna extension mounting kit (M1361A Option 1AA).

The kit contains:

- Antenna extension cable with BNC connectors (1.0m/3.3 ft. approx.)
- Mounting bracket, including fixings, for mounting onto Philips Carts.

The mounting bracket can also be fitted on walls, wooden carts, or other flat surfaces using fixings (not supplied) appropriate for the surface material.

Mounting on Philips Carts

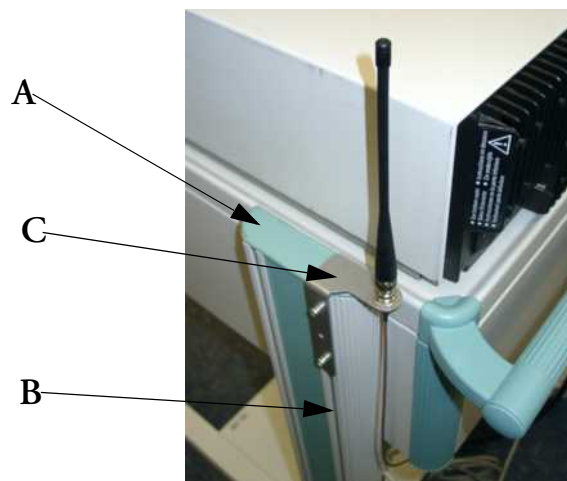

- 1 Remove the plastic cover (A).
- 2 Slide the fixings for the mounting bracket (C) into the groove (B) in the cart.
- 3 Replace the plastic cover (A) before sliding the mounting bracket fully down.
- 4 Slide the mounting bracket downwards in the groove (B) in the cart until the antenna holder part of the bracket rests on the plastic cover.
- 5 Tighten the fixing screws to secure the mounting bracket.

Mounting on Wooden Carts and Other Flat Surfaces



Considerations for Choice of Configuration

There are a number of factors that can influence how you finally configure the Avalon CTS.

Frequency Bands

Depending on the country of use, the system uses radio frequencies within one of three ranges, the Wireless Medical Telemetry Systems (WMTS) band, the Industrial, Scientific and Medical (ISM) band, or a range of bands specific to Japan. The actual approved frequencies used depend on country-specific regulations. The following diagram gives an example overview of the system's frequency band configuration.

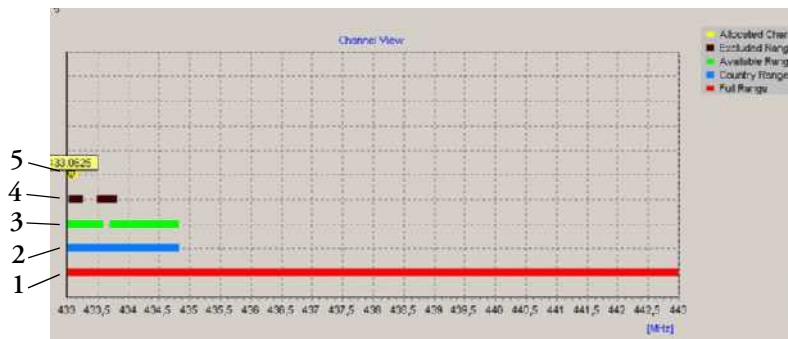

- 1 = The full (hardware) frequency range (10 MHz wide).
- 2 = The country-specific frequency range governed and approved by local regulatory bodies.
- 3 = The available frequency range: shows the real, current frequency range available within the country range. This will differ from the country range due to:
 - excluded frequency ranges
 - frequency ranges already allocated to other Avalon CTS systems in the same establishment.
- 4 = Excluded frequency ranges (ranges occupied by other telemetry systems, or other RF interferers).
- 5 = Fixed frequency ranges.

Standard Delivery Configuration

The Avalon CTS is normally delivered with:

- Automatic channel search.
- A standard antenna.

Using the standard antenna, the potential operating range is up to 100 meters/300 feet. The actual effective area of reach will vary according to the geographical and physical characteristics of the building where the system is installed, and is also influenced by the presence of other radio frequency (RF) devices or interference. We recommend that you define effective operating range prior to putting the system into operation.

If the area of reach is adequate for the intended monitoring area, and the system's operation is not influenced by other RF sources, then the normal delivery configuration is sufficient.

When is a Different Configuration Needed?

This section deals with possible reasons why the standard delivery configuration may not be adequate.

When the Area of Reach is Not Sufficient

If the area of reach is not sufficient using the standard antenna supplied with the system, there are a few things to consider:

- The placement of the antenna has an effect on the operating range. If it is located inside a metal cart or other RF-absorbing material, then place the antenna externally by using the Antenna Extension Mounting Kit (M1361A Option 1AA) to increase the range.
- Check the orientation of the antenna. In general, the antenna provides the greatest range when it is positioned vertically.
- If the area of reach is still insufficient, consider installing an antenna system.

When the Standard Configuration is Unsuitable

The standard configuration, with free base station channel search, may be unsuitable if:

- There are other telemetry or RF systems installed in the hospital.
- There are multiple (more than ten) stand-alone Avalon CTS systems.
- There are other sources of RF interference, for instance, broadcasting stations, microwave devices, and wireless temperature sensors.
- You connect the Avalon CTS to an antenna system.
- There are country-specific regulations requiring special configuration (in Japan, for example), or your country requires a Multi-Region base station.

Japanese Systems

Transducers must use fixed frequencies. They are initially shipped from the factory with no frequencies assigned to them. During installation, they are initialized, and their frequencies are set. (See also "Transducers for Japan" on page 66.)

Multi-Region Base Station

For countries requiring the Multi-Region base station (for example, Norway and Singapore), the receiver in the base station is “disabled” before it leaves the factory. The correct approved frequency range is then enabled locally during installation using the Service Support Tool. (See also “Multi-Region Base Station” on page 66.)

Frequency Planning

For Japan and countries using the Multi-Region base station, and for multiple cordless/telemetry installations in the same hospital, an RF frequency plan should be implemented. Document all frequencies or frequency ranges occupied by:

- Other telemetry systems (adult and fetal).
- Multiple Avalon CTS systems (operating on fixed frequencies). Remember that the Avalon CTS is also a potential interference source for other RF systems.
- Other sources of RF interference (other electrical equipment, broadcasting stations, or paging systems, for instance).

Once you have identified all the occupied frequencies or frequency ranges (for example, by using the Service Support Tool software) you can change the system’s configuration by following the guidelines for RF channel/frequency configuration.

- Exclude frequency ranges already occupied by other telemetry systems or that are subject to interference from other RF sources (see page 65).
- Use fixed frequencies for the base station, possibly in conjunction with altering the channel spacing (see page 74).
- Use fixed frequencies for the transducers (see page 66).

Setting Expectations

No matter how good a telemetry system design is, it will always experience occasional loss of radio communications, resulting in US/Toco/ECG dropouts. A telemetry system will never be as reliable as a hard-wired monitor that transmits its signal through a wire. If occasional loss of US/Toco/ECG monitoring is not acceptable for certain patients, they should be connected to a hard-wired bedside monitor.

WARNING Telemetry should not be used for primary monitoring in applications where the momentary loss of the US/Toco/ECG signal is unacceptable.

Following are guidelines to set proper expectations of hospital staff and to improve system performance:

- Clinicians will tend to see more motion related artifact on the US/Toco/ECG measurements of ambulatory patients than on patients that are restricted to a bed.
- Patients should be restricted to the designated coverage area. Monitoring performance will degrade if patients go outside the radius of coverage of the receiving antenna.

- Keep the size of the antenna system as small as possible. Telemetry system performance will degrade as the system size increases. The larger a system is, the greater the potential for receiving interfering signals. In addition, as more devices are added to the antenna system, the noise generated by the antenna system itself increases.
- A patient location protocol is critical to a telemetry system. If a life-threatening event occurs, the clinician must be able to locate the patient quickly. The importance of this increases as the antenna system size increases.
- Philips Medical Systems has no control over the RF environment in the hospital. If interference exists at the operating frequencies, telemetry system performance will be affected. Careful selection of frequencies for **all** wireless devices used within a facility (telemetry transmitters, walkie-talkies, ambulance radios, other wireless medical devices, etc.) is important to prevent interference between them. **Frequency management is the responsibility of the hospital.**

Antenna System Guidelines

The Avalon CTS (M2720A) is compatible with the dual band antenna system components used with the M2600A adult telemetry system. Antenna systems must be designed according to adult telemetry system rules, and presales activities and site preparation must be done according to the existing M2600A series antenna system rules. These activities are not bundled into the product price and have to be ordered separately from the Philips Medical Support Organization.

In addition to the M2600A antenna system design rules, the following antenna specifications apply to the Avalon CTS:

- Only original M2600A antenna system components will be supported.
- The antenna spacing must not exceed a radius of 10m (32ft).
- Existing antenna systems used for M1310A with 15.5m (51ft) antenna radius spacing do not comply and must be redesigned to work with the Avalon CTS.
- A mixture of Avalon CTS and other supported Philips telemetry devices (for example, M1310A or M2600A Adult Telemetry Transmitter/Receiver) on the same antenna system **may** be supported. Please see below for further details of how to configure and design a mixed telemetry system.
- Frequency converters used in USA with M2600A adult telemetry **cannot** be used with the Avalon CTS.
- Contact Philips Support regarding antenna system design.

Before You Install an Antenna System

In general, before each antenna system installation, a site frequency plan is required which includes an appropriate frequency plan for M2720A and all other telemetry devices used in the same hospital.

Using the results of this frequency survey, the appropriate frequency allocation mode must be set for the M2720A, for example, automatic frequency allocation mode or fixed frequency mode for the base station. Under normal circumstances, the fixed frequency mode for the transducer should not be used, except for Japan. See the *Service Support Tool Help* for further information about choices of frequency allocation modes.

An antenna system for the M2720A should be designed by an antenna expert experienced in designing M2600A antenna systems. For antenna system calculations, the specifications for M2720A can be added to the Antenna System Design Spreadsheet. This is important, because most antenna systems for the M2720A are non-standard in design, as the RF signal typically needs to be distributed to several rooms.

Specifications

Antenna system calculations for fetal telemetry differ from those of adult M1402A or M2602A mainframe systems. The M2720A uses an internal signal amplifier, requiring the antenna system to have a 0db to -3db gain at the final antenna connection to the Avalon CTS.

The minimum carrier to noise ratio (CNR) should be 8dB.

M2720A Avalon CTS typical specifications:

M2720A Frequency Band	Maximum Input Before Saturation	CNR	Gain	NF	TOI @100KHz	P1dB
ISM (433-443 MHz)	0 to -3db	8 dB	14.1 dB*	7.36*	5 dBm*	-4 dBm*
Japan (420-430 MHz)	0 to -3db	8 dB	14.6 dB*	6.86*	5 dBm*	-4 dBm*
WMTS (608-614 MHz)	0 to -3db	8 dB	11.1 dB*	8.55*	5 dBm*	-4 dBm*

*Can be added to the antenna design spreadsheet as M2720A-specific parameters

Mixed Telemetry Devices on the Same M2600A Antenna System

A mixture of M2720A and other supported Philips telemetry devices (for example, M1310A or M2600A Adult Telemetry Transmitter/Receiver) on the same antenna system are supported under the following conditions:

- M2600A antenna system design rules are followed.
- Antenna input must be within the range of 0dB to -3dB.
- Each Avalon CTS channel must be separated by a minimum of 100 KHz from any non-Avalon frequency channel.
- The internal channel frequency spacing between Avalon CTS transducers should be 25 KHz (factory default setting).

Example:

A Series 50 T Fetal Telemetry System (M1310A) is already connected to an antenna system, and its transmitter is set to 433.650 MHz. You need to connect an Avalon CTS to the same antenna system. In this case, the first usable frequency channel for any M2720A transducer is either 433.550 MHz or 433.750 MHz, as each transducer frequency channel must be separated by at least 100 KHz from any frequency channel used by any telemetry device other than Avalon CTS transducers.

Theory of Operation

This chapter describes the functional operation of the system, including the base station and transducers. It incorporates features of the mechanical design, indicating the physical relationship of the assemblies and components.

Base Station Hardware Overview

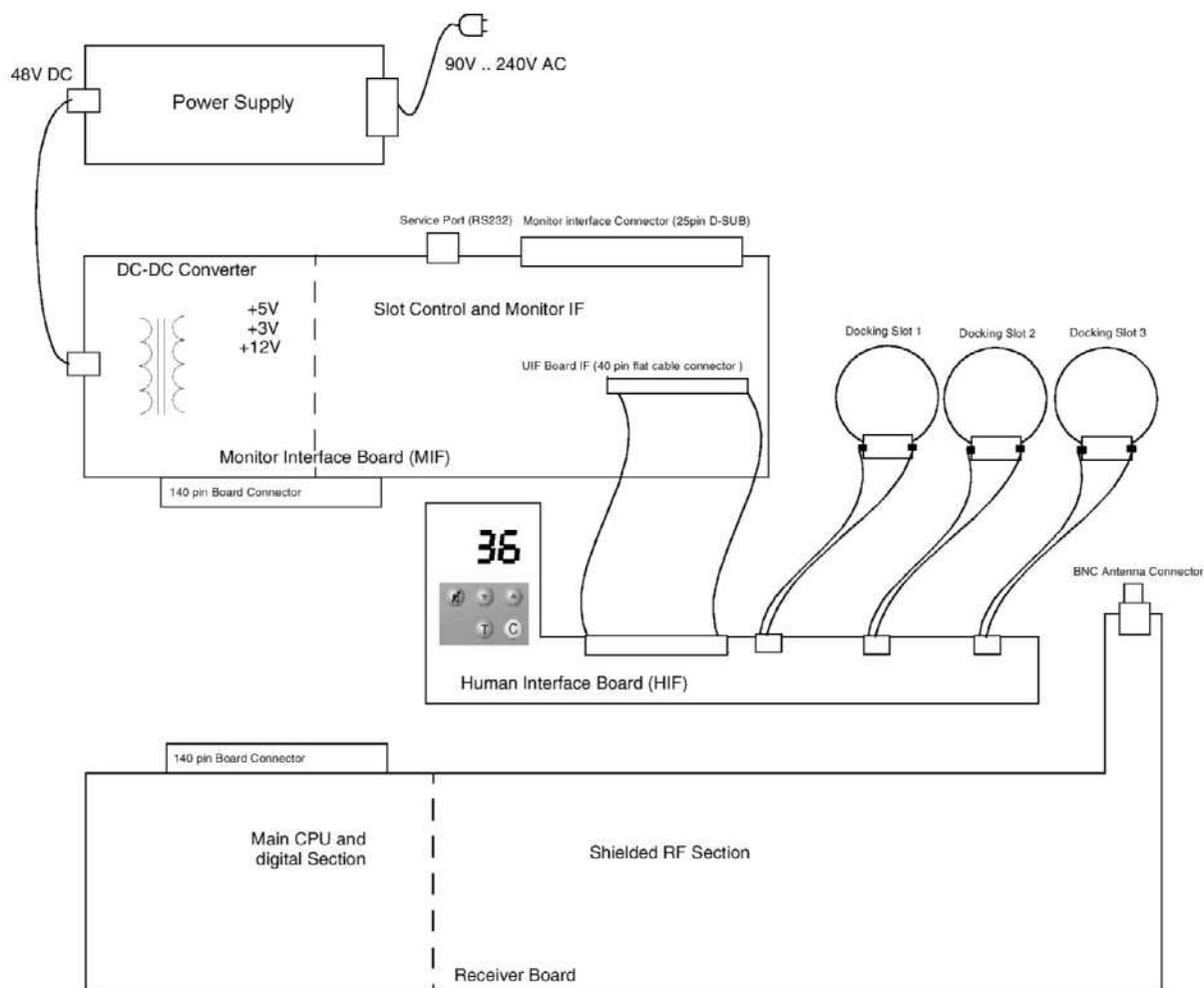

Figure 1 Base Station Boards

The Base Station consists of four functional components:

Receiver Board

The receiver is a double superheterodyne narrowband frequency modulation (FM) receiver, with two mixers and two intermediate frequencies (IFs). Three radio frequency (RF) signals can be received independently with three identical receiver channels. The digital section of the main CPU is responsible for frequency shift key (FSK) detection, analog-to-digital conversion of the low frequency (LF signal), signal filtering, and radio frequency (RF) channel management. The main CPU communicates with the transducers. While charge power is on, a serial communication link is established between the base station and each docking slot.

Human Interface Board

The Human Interface (HIF) board provides the user interface, and the display, indicators, keys and the slot charging contacts are all located on this board.

Power Supply

The power supply is a wide-range input switching unit, with an output of +48V. It is located on the chassis assembly.

Slot Control and Monitor Interface Board Hardware

The Monitor Interface (MIF) board provides the interface to the fetal monitor as well as the communication interface to the transducer slots. Power conversion is performed by a DC-DC converter. The digital (active) parts of the human interface also reside on this board.

The MIF board consists of the following functional blocks:

- **DC-DC Converter** - the 48V DC input for the DC-DC converter comes from the primary AC-DC converter. Since the 48V DC voltage is sufficiently stabilized, two fixed pulse width step down transformers are used to transform the high voltage down to the required 3V, 5V and 12V (post-regulated for accuracy).

The +12V supply is mainly used for battery charging and you can access this voltage at the charge contacts. The fuse on the MIF board are not replaceable, and if it blows, the board must be replaced. If there is a short to ground, unlimited current will blow the fuse. To avoid this, a current limiter is used to limit the output current.

- **Monitor interface** - three major blocks make up the monitor interface:
 - PWM Toco digital-to-analog (D/A) converter
 - Two PWM wave D/A converters for FHR low frequency (LF) 1, and FHR LF 2.
 - Digital status ports
- **Transducer slot interface** - this block is responsible for transducer detection, safety features of the charge power switch, serial communication between base station and transducers and synchronization clock generation for the power supply. To ensure that there is no charge power applied to the charge contacts when there is no transducer docked in a slot, charge power in each slot is only applied after a transducer has been detected.
- **Drivers for the HIF board interface** - this block contains the multiplexing and driving components for the function buttons, the display backlight and the seven-segment LEDs.

Transducer Hardware Overview

The system has three transducer types:

- Toco
- US
- ECG

They all share the same modulation and digital processor circuitry, power supply, liquid crystal display, and RF transmitter. The processor software is also the same for all transducers. The frontends, however, are specific to each transducer type.

Functional Description of the RF/CPU Hardware

The RF/CPU section of the transducers is made up of the following functional blocks:

- CPU (micro controller)
- LCD
- Base Station communication
- EEPROM
- FLASH download port
- Clock generator
- Power supply and battery charger
- Modulator
- RF transmitter

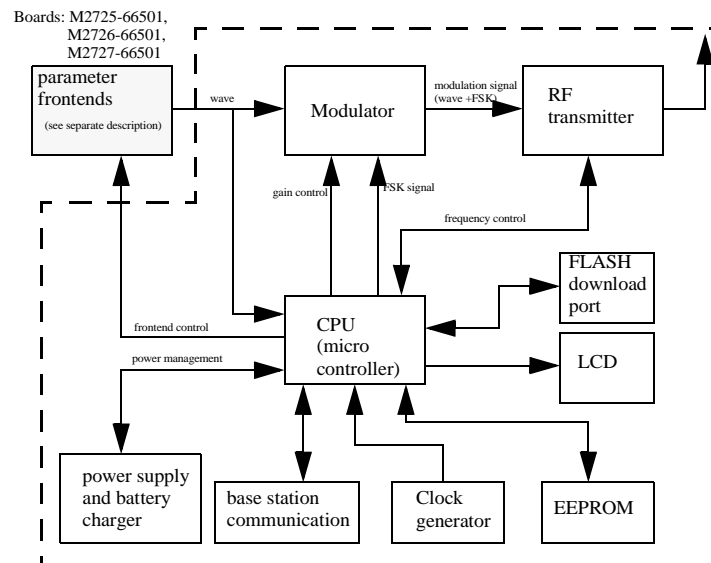

Figure 2 Transducer Block Diagram

Base Station Communication

An active base station communicates with docked transducers to check the correct transducer type, serial number, to program the RF frequency, to initiate test cycles, and to check the current battery status.

Power Supply and Battery Charger

A Lithium-Ion (Li-Ion) battery powers the transducer. Batteries are charged whenever a transducer is docked in an base station connected to AC power. Charge power is transferred by the spring-loaded, two-pin charge contacts. Communication between the base station and the transducer processors is also done using these contacts.

An intelligent Li-Ion charging circuit in the transducer controls the battery management. See page 72 for battery charging times.

Modulator

The analog heart rate signals (ultrasound Doppler or fetal ECG) are pre-processed and band-limited by filters. The signals are then fed into a programmable gain amplifier controlled by an automatic gain control circuit and a digital FSK modulated subcarrier (1.6 kHz or 2.4 kHz) is added to the RF carrier signal. The subcarrier is responsible for the digital transmission of the Toco data, along with safety and status information, such as serial number, bed label, fetal movement data, battery information.

RF Transmitter

The RF transmitter block contains:

- a PLL synthesizer that divides the reference frequency down to 12.5 kHz, and can be tuned in steps of 12.5 kHz.
- a voltage controlled oscillator (VCO).
- a power amplifier (antenna driver).

Toco Frontend Hardware

Uterine activity is measured by evaluating the hardness of the mother's abdomen with a pressure sensitive resistor bridge (DMS element). The DMS element requires an excitation voltage and its differential output signal is proportional to the pressure applied to the DMS element. An AC excitation voltage is used, and the resulting AC output signal is amplified and converted to a pressure proportional DC voltage by a synchronous rectifier followed by a low pass filter.

Ultrasound Frontend Hardware

The ultrasound frontend is a pulsed Doppler system with a 1.0 MHz ultrasound frequency, and a pulse repetition rate of 3.2 kHz. Seven ultrasound crystals are used as transmitter and receiver.

ECG Frontend Hardware

Several parameter frontends are combined on the ECG frontend board. Currently supported parameters are DECG and MECCG.

A seven-pin 'D-type' socket carries all parameter related inputs and outputs. An external mode resistor, connected to one of the pins, detects which ECG mode to set when an adapter cable is plugged in. The M1362B ECG adapter cable, used with the M1364A patient module, is also used for the fetal scalp or adult electrodes.

System Interfaces

The Avalon CTS has two system interfaces:

- Fetal monitor interface
- Service Interface

Fetal Monitor Interface

The Fetal Monitor Interface on the base station allows digital and analog outputs to the Series 50 fetal monitors. The interface is enhanced to support additional transducer combinations for future fetal monitors.

The following table lists the signals at each pin.

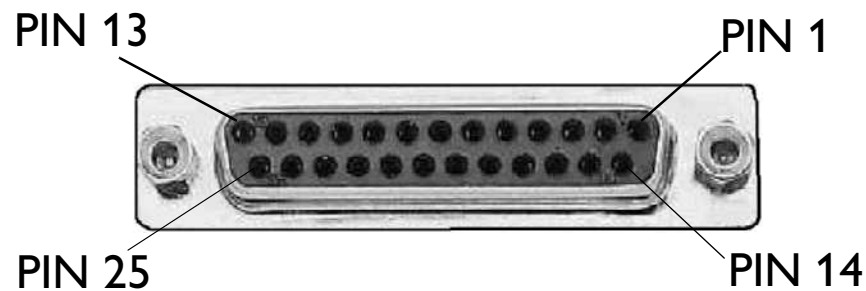

Pin	Signal Details
1	MECG supported (Series 50 B/C fetal monitors only).
2	+3V RF (10 k Ω internal resistance)
3	+12V RF (10 k Ω internal resistance)
4	+48V RF (100 k Ω internal resistance)
5	Base station on (L).
6	Reserved.
7	DECG inop (L).
8	DECG Mode (L).
9	Reserved for future functionality.
10	US Mode (L).
11	Reserved.
12	IUP Mode (L).

Pin	Signal Details
13	TOCO External Mode (L).
14	US LF or ECG Signal.
15	TOCO/IUP signal.
16	Not connected.
17	Ground.
18	Ground.
19	Reserved. (Tele-Marker on the fetal monitor side.)
20	Tele-FMP on (L) if FMP available.
21	Tele-Fetal movement on (L).
22	MECG Inop.
23	Not connected.
24	Ground.
25	MECG Mode.

Service Interface

The service socket on the rear of the base station takes a stereo phone jack for RS232 connection to an industry standard compatible PC installed with the Service Support Tool software. Use the interface cable M1350-61675. The transducers must be docked in the base station for communication with the Service Support Tool.

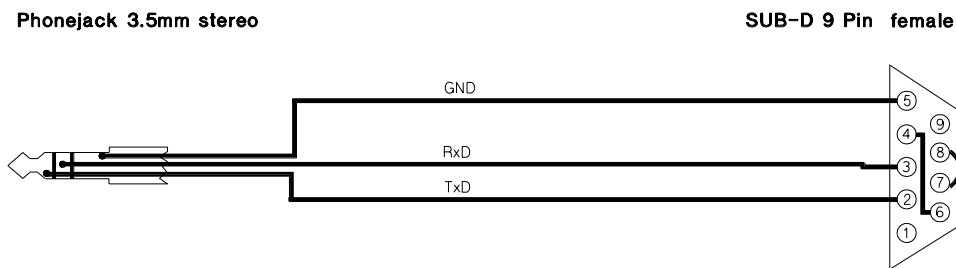

Figure 3 Interface cable for connecting an industry standard compatible PC to the Avalon base station.

Compatible Fetal Monitors

A list of compatible fetal monitors (including interfaces) is given in the following table.

Monitor / Interface (IF)	Parameter					Comments
	US	FMP	DECG	MECG	Toco	
M1350x with M1350-66531 IF	HR 1	-	HR 1	✓	✓	Only one FHR is transmitted.
M1350x with M1350-66536 IF	HR 1	✓	HR 1	✓	✓	Software revision A.04.01 or greater.
M1351A with M1353-66531 IF	HR 1	-	-	-	✓	No ECG processing. DECG mode generates "Err 9".
M1351A with M1353-66531 E IF	HR 1	✓	-	-	✓	Software revision A.02.00 or greater.
M1353A with M1353-66531 IF	HR 1	-	HR 1	-	✓	Only one HR transmitted.
M1353A with M1353-66531 E IF	HR 1	✓	HR 1	-	✓	Software revision A.02.00 or greater.
Key: ✓ = supported; - = not supported						
*M1351A is not able to measure DECG/MECG						

Disassembly/Reassembly

-
- WARNING**
- Performance verification: do not place the system into operation after repair or maintenance has been performed, until all performance tests and safety tests listed in Chapter 6 of this service manual have been performed. Failure to perform all tests could result in erroneous parameter readings, or patient/operator injury.
 - Energized circuits are accessible with the covers open. Do not work on the base station with the covers open and AC power connected. Only qualified service personnel should open or disassemble the base station.
 - Before attempting to open or disassemble the base station, disconnect it from the AC mains supply.
-

CAUTION Observe ESD (electrostatic discharge) precautions when working within the unit.

Introduction

Remember to store all screws and parts in a safe place for later refitting.

How to Use this Chapter

The disassembly sections detail the step-by-step procedures you use to access replaceable parts of the base station.

All the transducers are sealed at the factory and are not repairable. Replacement transducers are supplied complete with both battery and belt button fitted.

The Avalon base station consists of two major assemblies:

- The top cover assembly
- The chassis assembly

The top cover assembly contains the human interface (HIF) board, the keypad inlay, and the battery charge contacts and wiring. The top cover assembly is only available as a complete assembly, and a repair to any part of the top cover assembly is effected by replacement of the whole assembly.

The chassis assembly contains the metal chassis and power supply, the receiver board and the monitor interface (MIF) board. The power supply always comes complete with the chassis (without boards), and a repair to either the power supply or the chassis is effected by replacement of this chassis/power supply assembly.

There are no boards available individually as replacement parts. In the case of a defective receiver board or MIF board, a repair is effected by exchanging the whole base station assembly (unit exchange).

All part numbers of spare parts are listed in Chapter 5.

Tools Required

CAUTION When replacing the front cover, do not over-torque the screws. Excessive torque may damage the plastic screw mountings.

You need the following tools:



•Torx-head screwdriver, size T-10

or

•Torx bit, for suitable driver, size T-10

Removing the Top Cover Assembly

- 1 Carefully place the base station upside down. To avoid scratches, place the unit on some cloth or other soft surface.

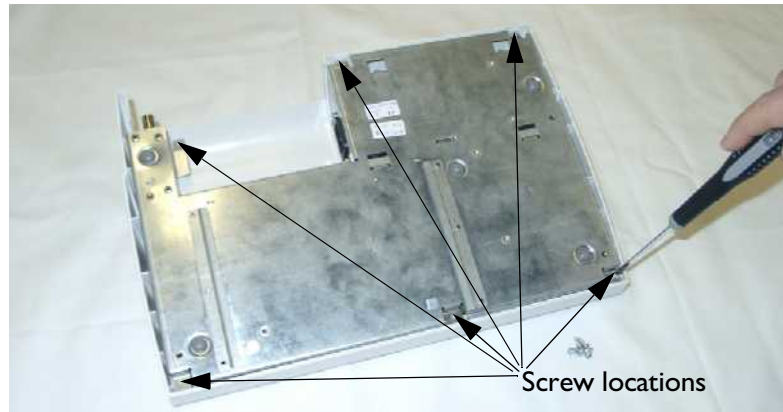

- 2 Remove the six screws securing the top cover assembly to the chassis, using a T-10 Torx driver.
- 3 Holding both top cover and chassis assemblies together, place the base station upright again.

- 4 Lift the front edge of the top cover and disconnect the spade connector for the ESD ground wire from the terminal on the metal chassis.



- 5 Now raise the cover a little more, and disconnect the multipin connector of the ribbon cable from the MIF board. Pull straight up to avoid bending the pins. The top cover assembly is now free of the chassis assembly.

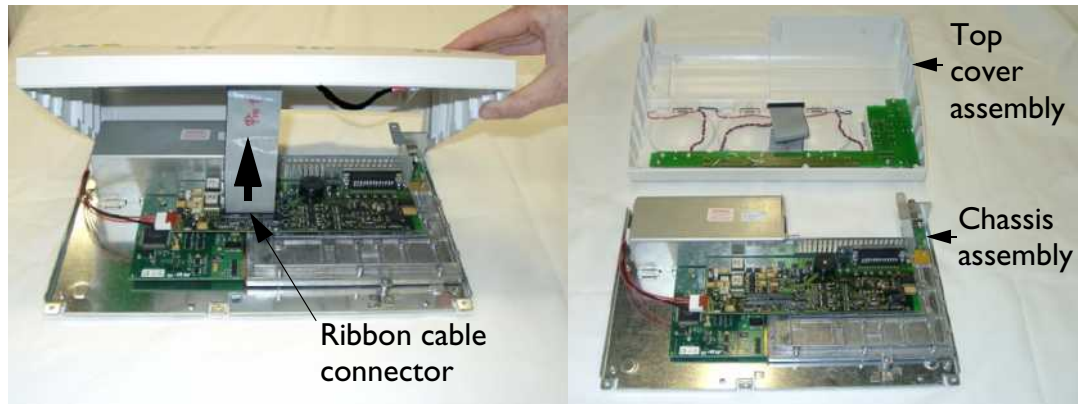

Replacing the Top Cover Assembly

The serial number appears initially in two places on the base station - on the rear of the top cover assembly, and on the bottom of the metal chassis. A replacement top cover does not carry a serial number.

- 1 Ensure all items are replaced in the top cover assembly.
- 2 Reconnect the multipin ribbon cable connector to the socket on the MIF board.

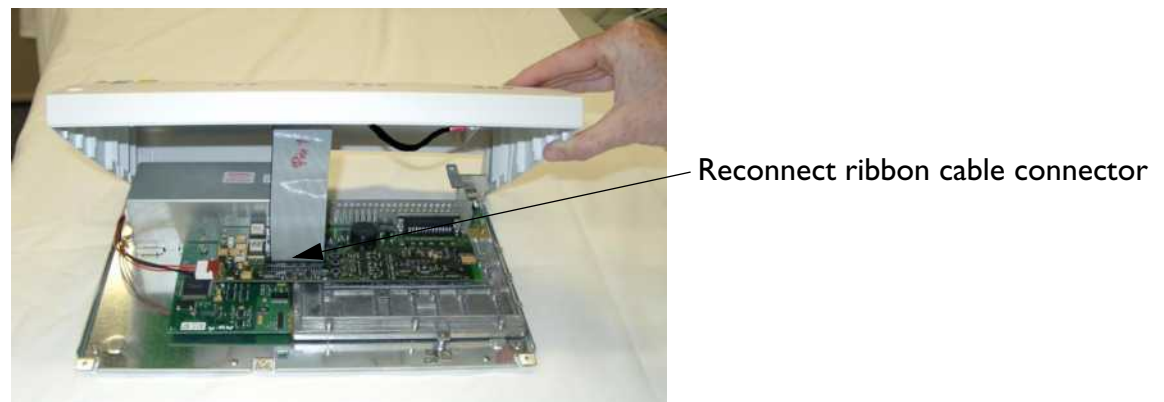

- 3 Important! Reconnect the ESD ground wire spade connector to the terminal on the chassis.

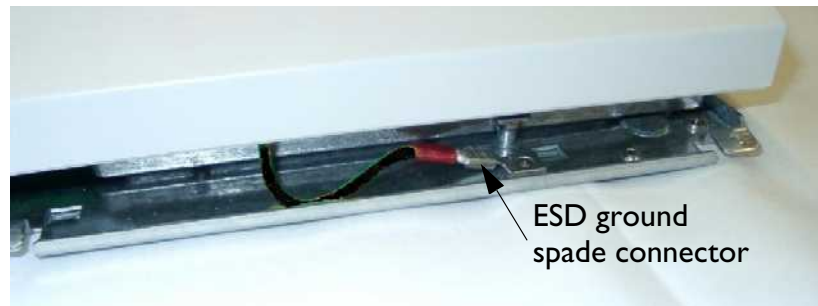

- 4 Place the front cover back to its normal position.
- 5 Holding both assemblies together, carefully place the unit upside down, preferably on a soft surface to prevent scratching or other damage.

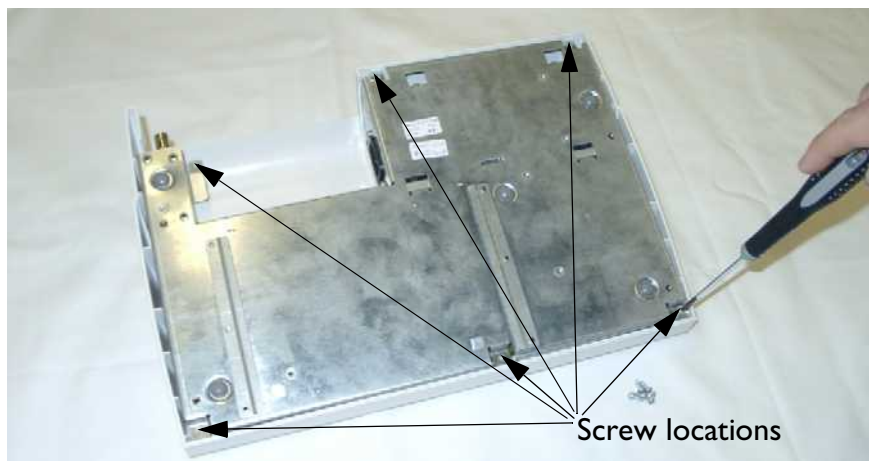

- 6 Make sure the screw holes in the metal chassis align with the screw mountings in the top cover moulding.

CAUTION When replacing the front cover, do not over-torque the screws. Excessive torque may damage the plastic screw mountings.

- 7 Drive in the six screws that hold the front cover and chassis assemblies together using a T-10 Torx driver.

Changing Fuses

There are two versions of power supply, the Celestica version (earlier build), and the Frei version (later build).

There are two field-replaceable fuses located in the power supply. They are of type T1.6A. **In the photographs that follow in this section, the MIF and receiver boards are removed for clarity, but the power supply cover can be removed with the boards in place.** To gain access to the fuses:

- 1 Remove the top cover assembly (see page 26).

- 2 Remove the three screws securing the power supply cover.

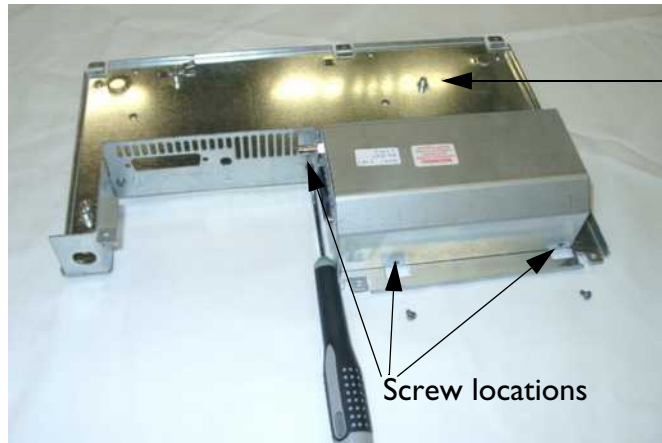

- 3 Unplug the connector for the power supply cable from the power supply.



- 4 Slide the power supply cover to the edge of the chassis, as shown, to clear the lugs on the chassis.

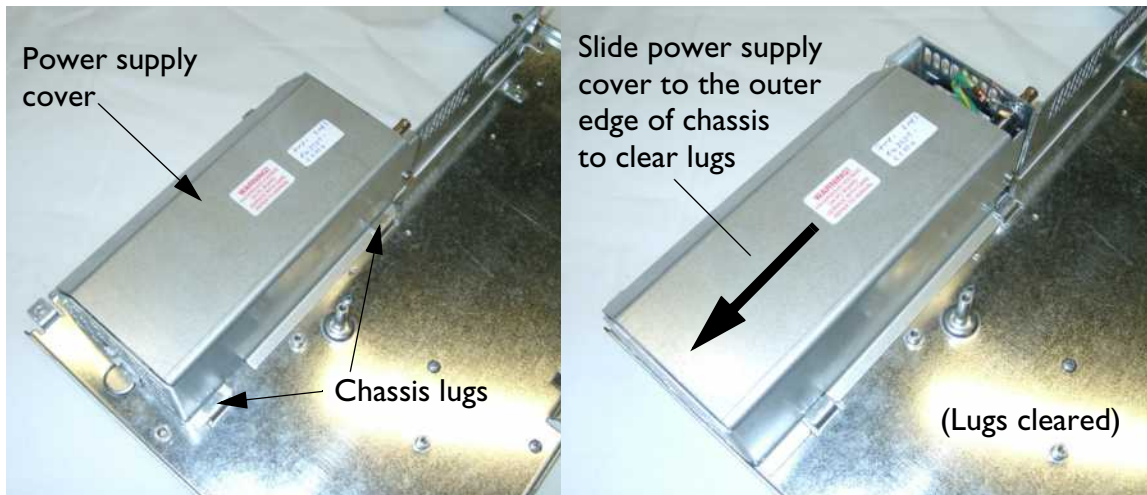

- 5 Then remove the cover by lifting it straight up.



6 Important! Replace the fuses with new fuses of exactly the same type and rating (T1.6A).

**FREI
version**



**CELESTICA
version**



7 Replace the power supply cover, and secure it with the three screws.

- 8 Reconnect the power supply cable connector to the power supply.
- 9 Replace the top cover assembly (see page 27).

Changing the Power Supply/Metal Chassis Assembly

The power supply and the metal chassis come as one unit (they are not available independently). The power supply cable is reusable, and also comes with the new chassis/power supply assembly.

To change the power supply/metal chassis assembly:

Step1: Remove the Top Cover Assembly

See page 26.

Step2: Remove the MIF Board

- 1 Remove the six-pin power supply connector from the MIF board.



- 2 Remove the two screws (A) using a T-10 Torx driver.

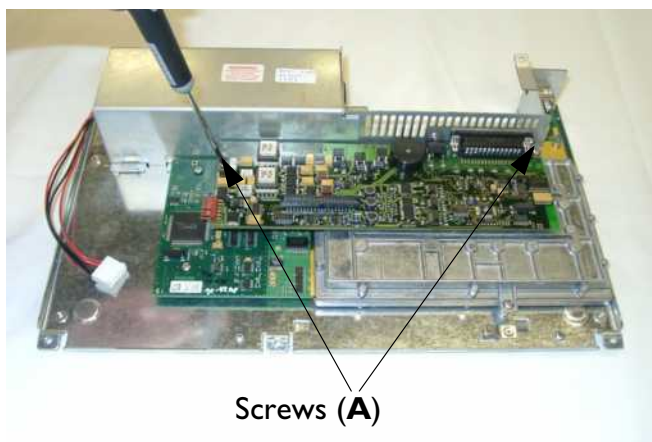

- 3 Then remove the two screws (B) for the fetal monitor interface socket using a 6mm socket driver.

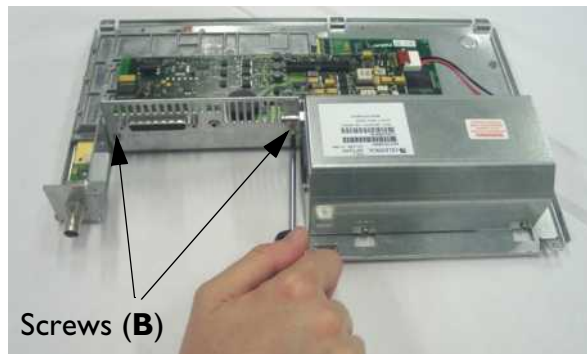

- 4 Disconnect the multipin connector joining the MIF board to the receiver board by lifting the corner of the MIF board nearest to the power supply cover.

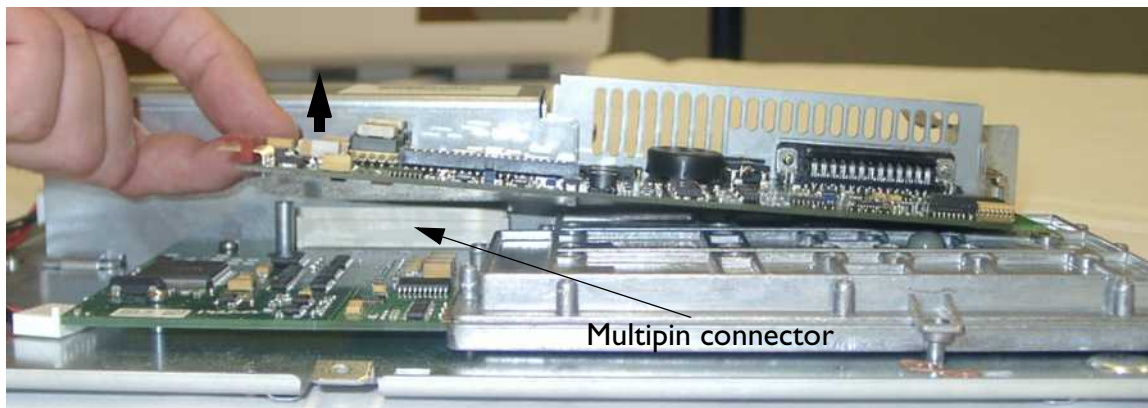

- 5 Then lift the MIF board clear of the chassis assembly.

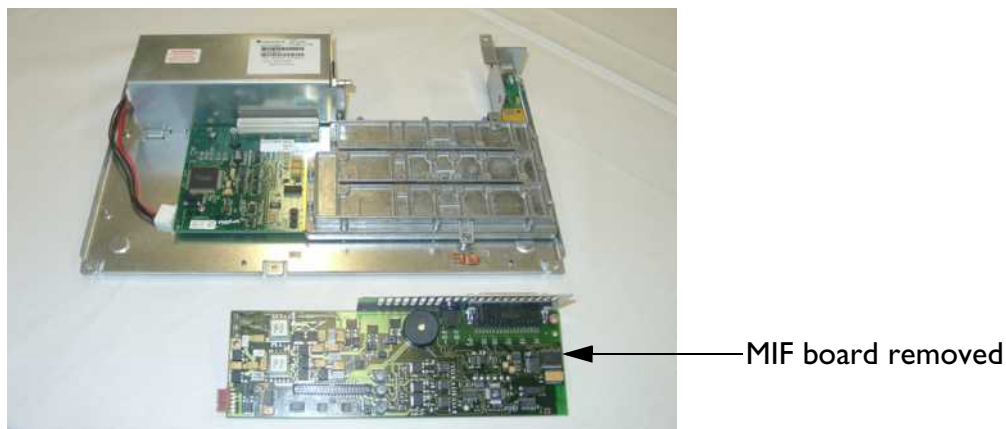

Step 3: Removing the Receiver Board

- 1 First remove the MIF board (see Step 1).
- 2 Remove the four screws securing the receiver board to the chassis using a T-10 Torx driver.

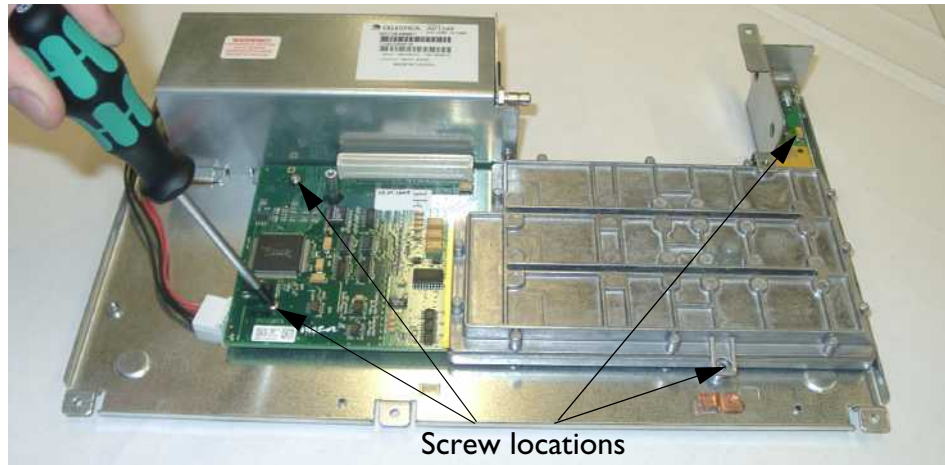

- 3 Gently lift the front right hand corner of the receiver board, at the same time pulling it forward.

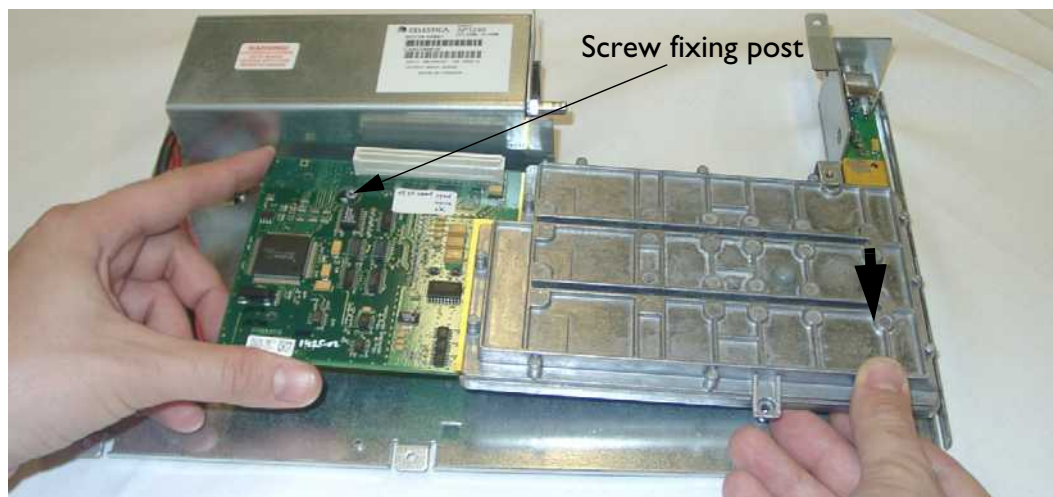

- 4 Next, lift the rear left hand corner of the board so that the board is clear of the metal screw fixing post.

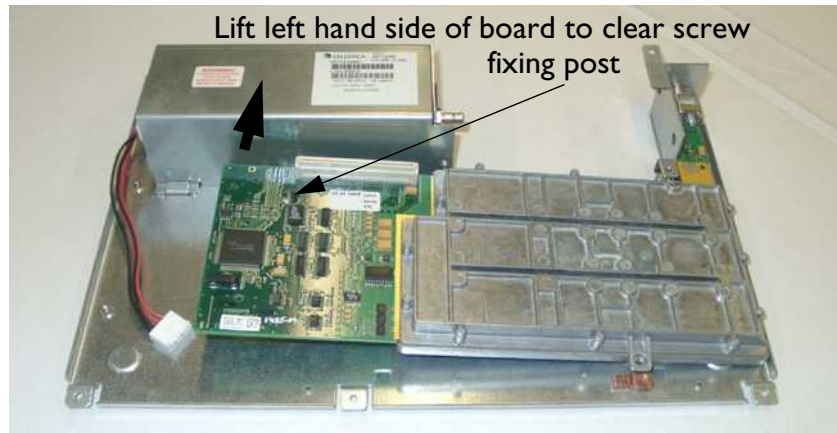

5 Then lift the board clear of the chassis.



Step 4: Replace Metal Chassis/Power Supply Assembly

Take the new metal chassis assembly.

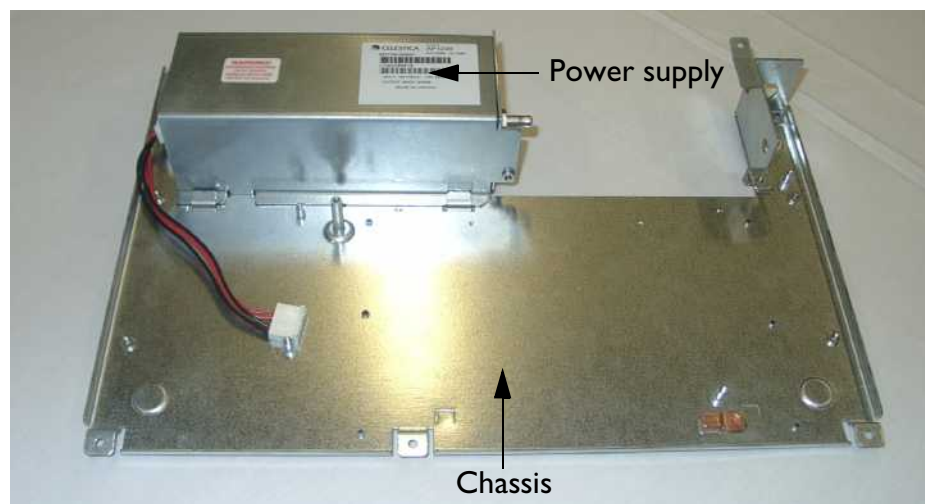

Step 5: Replacing the Receiver Board

- 1 Insert the antenna socket into its aperture in the new metal chassis and locate the metal screw fixing post through the hole in the left hand side of the receiver board.

Locate screw fixing post through hole in board



Insert antenna socket through hole in chassis

- 2 Position the receiver board so that all the screw holes on the board align with the screw fixing points on the chassis.

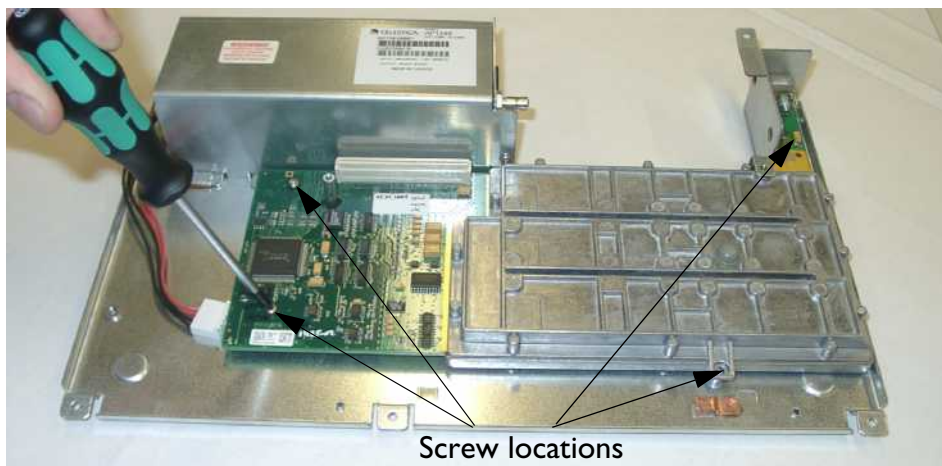

Screw locations

- 3 Drive in the four screws (A) using a T-10 Torx driver to secure the receiver board to the chassis.

Step 6: Replacing the MIF Board

- 1 Carefully locate the multipin connector plug, on the underside of the MIF board, in the socket on the receiver board, ensuring it is accurately aligned.

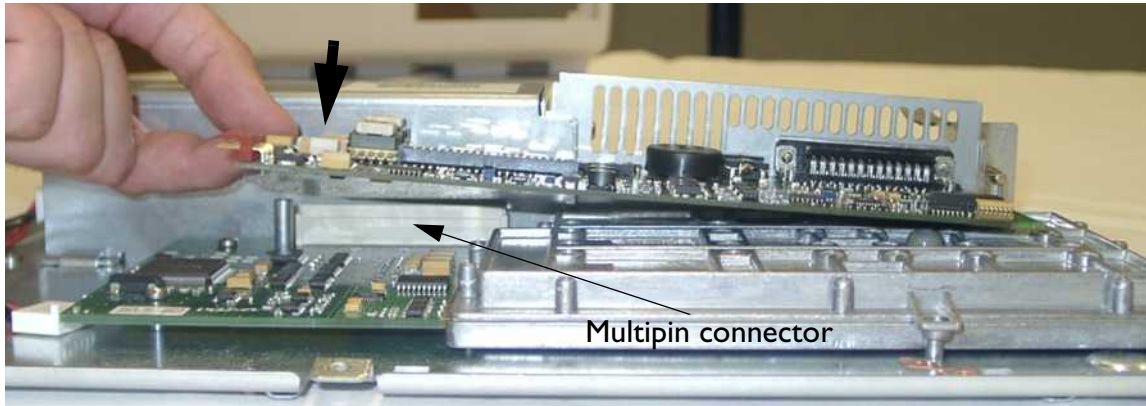

- 2 Carefully apply a little pressure on the left hand rear corner of the MIF board to seat the multipin connector into the socket on the receiver board below.
- 3 Ensure that the screw holes in the board align with the screw fixing points below.
- 4 Drive in the two screws (B) with a T-10 Torx driver.

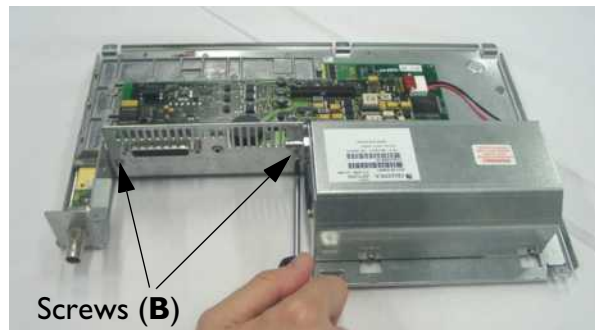

- 5 Then drive in the two screws (A) using a T-10 Torx driver. The MIF board is now secure.

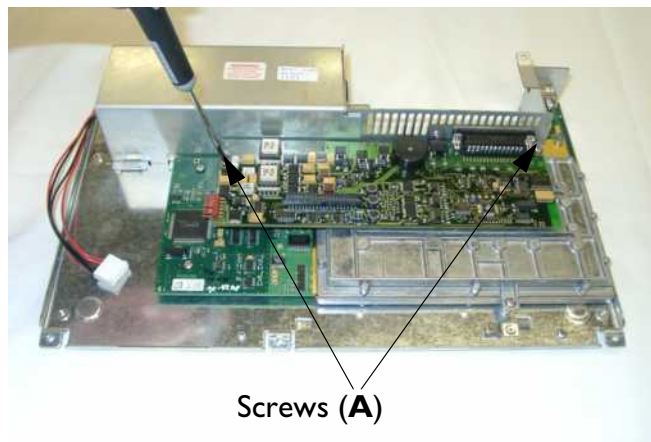

- 6 Reconnect the power supply connector plug to the socket at the front left hand corner of the MIF board.

Reconnecting
six-pin power
connector



Step 7: Replace The Top Cover Assembly

Replace the top cover assembly taking care not to over-torque the screws (see page 27).

Spare Parts

Spare parts, along with part numbers, are listed in the tables that follow.

All transducers and accessories are latex-free, unless indicated otherwise in the tables below.

Exchange Parts

Exchange Part Number		New Part Number		Description
"5x5"	12 NC	"5x5"	12 NC	
M2720-69030	453563474101	M2720-60030	453563473001	Base station (without transducers) - WMTS*
M2720-69031	453563474111	M2720-60031	453563473011	Base station (without transducers) - ISM*
M2720-69032	453563474121	M2720-60032	453563473021	Base station (without transducers) - Japan*
M2720-69034	451261002071	M2720-60034	451261002061	Base station (without transducers) - Multi-Region (for example for Norway, Singapore*)
M2725-69001	453563474341	M2725-60001	453563474301	Cordless Toco transducer - USA/Australia
M2725-69002	453563474351	M2725-60002	453563474311	Cordless Toco transducer - Europe
M2725-69003	453563474361	M2725-60003	453563474321	Cordless Toco transducer - Canada
M2725-69004	453563474371	M2725-60004	453563474331	Cordless Toco transducer - Japan
M2726-69001	453563474421	M2726-60001	453563474381	Cordless US transducer - USA/Australia
M2726-69002	453563474431	M2726-60002	453563474391	Cordless US transducer - Europe
M2726-69003	453563474441	M2726-60003	453563474401	Cordless US transducer - Canada
M2726-69004	453563474451	M2726-60004	453563474411	Cordless US transducer - Japan
M2727-69001	453563474501	M2727-60001	453563474461	Cordless ECG transducer - USA/Australia
M2727-69002	453563474511	M2727-60002	453563474471	Cordless ECG transducer - Europe
M2727-69003	453563474521	M2727-60003	453563474481	Cordless ECG transducer - Canada
M2727-69004	453563474531	M2727-60004	453563474491	Cordless ECG transducer - Japan

*See "Antenna and Base Station Part Numbers" on page 41.

Non-Exchange Parts

Part Number		Description
"5x5"	12 NC	
M2720-67701	453563474091	Base station metal chassis (housing bottom) including power supply and DC cable
M2720-64003	453563474081	Base station top cover assembly including warning label and screws
2110-0495CP	453563071821	Fuses for power supply T1.6A
0950-2028	453563044001	Antenna. See ""Antenna and Base Station Part Numbers"" on page 41".
0950-2029	453563044011	
1250-0076	453563473991	BNC connector, 90 degrees
M2720-64001	453563474061	Battery replacement kit (includes tool and instruction sheet)
M2720-64002	453563474071	Knob replacement kit, contains three knobs (includes tool and instruction sheet)
M2720-03201	453563474041	Mounting brackets

Supplies and Accessories

Part Number		Description of Supplies/Accessories
"5x5"	12 NC	
15133D	989803100741	Fetal scalp electrode (EU and Asia-Pacific version) - shipment country dependent
15133E	989803100751	Fetal scalp electrode (US version) - shipment country dependent
40483A	989803101601	Aquasonic US gel
40493E	989803101681	Electrodes (pre-gelled)
M1349A	989803103421	Disposable fetal adhesive pad electrode
8120-2961	453563198651	Ground cable with clamp
8120-4808	453563199211	ground cable IEC
M2720-61603	453563474051	Interface cable (for connecting the Avalon CTS to a fetal monitor)
M2725A	862488	Cordless Toco transducer
M2726A	862489	Cordless US transducer
M2727A	862490	Cordless ECG transducer
M1362B	989803103551	DECG adapter cable
M1363A	989803103561	MECG adapter cable (for use with M1364A or M1365A)
M1562A	989803104111	Fetal belts, washable (pack of 3, contain latex)
M1562B	989803129891	Waterproof fetal belts, washable (pack of 3)
M2208A	989803106021	Disposable abdominal belts (case of 100)
M1360-61675	453563277381	PC service cable for Service Support Tool

Antenna and Base Station Part Numbers

Frequencies for medical telemetry devices are not yet harmonized. Consequently, frequencies vary according to country-specific regulations, and are subject to change.

Band	Antenna Part Number		Base Station Part Numbers			
			Exchange Parts		New Parts	
			'5x5'	12 NC	"5x5"	12 NC
WMTS Band (internal code #214)	0950-2028	453563044001	M2720-69030	453563474101	M2720-60030	453563473001
ISM Band (internal code #212)	0950-2029	453563044011	M2720-69031	453563474111	M2720-60031	453563473011
Japanese Band (internal code #215)	0950-2029	453563044011	M2720-69032	453563474121	M2720-60032	453563473021
Multi-Region Base Station - ISM Band (uses #212 hardware)	0950-2029	453563044011	M2720-69034	451261002071	M2720-60034	451261002061

Preventive Maintenance and Safety

This chapter contains maintenance and safety information for the Avalon CTS and accessories.

All checks that require the instrument to be opened must be made by qualified service personnel. Contact your local Philips representative if you wish safety and maintenance checks to be carried out by Philips personnel.

To ensure proper functioning of your system you must adhere to the standards described in this book for:

- Cleaning
- Performance assurance checks (system self test, parameter test)
- Safety tests (safety test blocks, instrument safety test, system test)
- Accessory testing (transducer checks, patient module checks)

CAUTION Failure on the part of the responsible individual hospital or institution using this equipment to implement a satisfactory maintenance schedule may cause undue equipment failure and possible health hazards.

Care and Cleaning

For detailed instructions on how to care for and clean the base station, transducers and the monitoring accessories, see the *Instructions for Use*.

Recommended Frequency of Testing

Perform the procedures as indicated in the suggested testing timetable. These timetable recommendations do not supercede local requirements.

Suggested Testing Timetable	
Test	Frequency
Performance Assurance (see page 44) and Safety Checks (see page 45).	Once a year (or as specified by local laws) and after repair where the power supply is replaced.
Regular Preventive Maintenance (see page 51).	Once a year or after repair.
Battery Check (see page 53).	As necessary.



Performance Assurance Tests

Self Test

The system performs a basic-level self test when you switch it on. You hear a beep, and all the display elements are shown for about one second, and then the display reverts to normal display mode.

Parameter Test

This tests the entire signal path from the individual transducers connected via radio frequency, through the base station, to the fetal monitor with artificially generated test signals. We recommend you perform this test once a day, and whenever you doubt the reliability of the measurements. The parameter test does not test the transducers themselves, there is a separate test for this (see “Testing Transducers” on page 67).

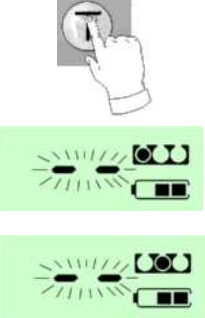
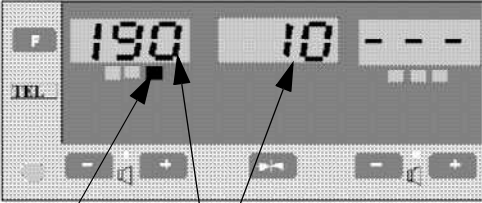
 <p>Base station display</p>	<p>In this example, one US transducer and one Toco transducer are docked. No other transducers are active.</p>
 <p>Ultrasound transducer display (slot 1)</p>	<p>Initial displays appear as shown. The battery indicator is lit on the base station.</p> <p>The bed label is visible on both displays.</p>
 <p>Toco transducer display (slot 2)</p>	<p>The transducer display shows which slot is occupied.</p>
	<p>To start the test, with no transducers or alarms active:</p> <ol style="list-style-type: none"> 1 Press and hold down T. The test mode remains active for as long as you keep T pressed. Battery charging stops, and the transducers behave like normal, active transducers. However, to differentiate between test mode and normal operation of a registered transducer, the two-digit numeric display in the LCD window shows the two segment bars (--) blinking. If you remove a transducer while the parameter test is still in progress, the transducer shuts down.
 <p>Signal quality</p> <p>Value of artificial signal</p> <p>Artificial HR signal</p>	<ol style="list-style-type: none"> 2 Each transducer transmits an artificial signal, via the programmed RF channel, to its registered slot on the base station. After decoding and processing, the artificial signals are fed via the analog connection to the telemetry interface input of the fetal monitor. The signals coming from the base station are then processed and displayed by the fetal monitor.

- 3 Check the values displayed by the fetal monitor to get an overview of the condition of the entire system. The following table specifies the signals that are generated during the test. As the mode of the ECG transducers is unknown to the base station (as it is configured outside of the base station), an ECG transducer is always mapped to the MEEG mode. This avoids potential mode errors.
- 4 To stop the test, release the **T** key.

Expected signals generated during the system test:

Test Outputs	US		DECG* (Place in Slot 1)	TOCO (Place in Slot 2)	ECG Transducer is in Slot 2	MEEG* (Place in Slot3)
	Slot 1	Slot 3				
Value on fetal monitor LED display, Recorder, OBMS-IF	190 bpm	170 bpm	200 bpm Note: Ensure there is no US transducer in slot 3 (Error 9 will appear)	 Signal with 30 units amplitude range and 20s period duration	An IUP reading appears on the fetal monitor. IUP measurements are not currently supported. Disregard any measurement you get.	120 bpm
Fetal monitor speaker	Artificial HR signal			N/A	N/A	“click”
Test tolerance**	+/- 2.5 bpm		+/- 2.5 bpm	+/- 10% period duration	N/A	+/- 2.5 bpm

*Test ECG transducers **without** the adapter cables attached.

**Signal is variable. Jitter should normally be within +/- 2.5 bpm. However, this could possibly be higher due to external factors, such as interference or the environment. On slot 1, the jitter can be higher than on slot 3.

Testing Alarms

Details of how to test alarms is given in the *Instructions for Use*.

Safety Tests

This section defines the test and inspection procedures applicable to the Avalon CTS Cordless Fetal Transducer System. Use the tables in the following section to determine what test and inspection results must be reported after an installation, upgrade, or repair has been carried out.

- Test Blocks in Table 1 tells you when to carry out the safety tests.
- Test and Inspection Matrix in Table 2 tells you how to carry out the safety tests.

WARNING Safety test requirements are set according to international standards, such as IEC/EN 60601-1 and IEC 60601-1-1, their national deviations, such as UL2601-1, CAN/CSA-C22.2 No. 601.1-M90 and No 601.1-S1-94, and specific local requirements.

The safety tests detailed in this chapter are derived from international standards but may not be sufficient to meet local requirements.

CAUTION The correct and accurate functioning of the equipment is ensured by the successful completion of the safety tests, performance test, and the system test.

Safety Test Procedures

The test procedures outlined in this section are to be used only for verifying the safe installation or service of the product in its place of use. The safety tests described here refer specifically to installation, setup, repair and upgrade activities, and not to the aspects of safety that have already been tested during final acceptance at the factory.

Use safety testers complying with IEC 60601-1 internationally, or any local regulations applicable to the country of the installation. For safety test procedures see the operation instructions of the safety tester used, and follow any local regulations.

If you use the Metron safety tester, the Metron Report should print results as detailed in this chapter, along with other data.

For information and ordering guides for Metron products contact:
Metron AS, Vegamot 8, N-7048 Trondheim, Norway
www: <http://www.metron-biomed.com>

When to Perform Safety Tests

This table tells you when to perform specific safety tests. See page 47 for test details.

Table 1: M2720A: When to perform safety test blocks

Service Event	Test Block(s) Required - Complete These tests
<p>Installation The product is customer installed. For installation instructions refer to the <i>Instructions for Use</i> for your monitor.</p>	Perform Visual, Power On, Performance and Safety test blocks (see Table 2).
<p>Preventive Maintenance Preventive maintenance is the responsibility of the customer (see page 51).</p>	Perform Visual test block (see Table 2).
<p>Repair This Service Guide contains repair instructions for the Avalon CTS.</p>	Perform Visual, Power On and Performance test blocks (see Table 2), and whenever power supply or fuses are removed/replaced, perform Safety test block.
<p>Upgrade For upgrade information refer to “Upgrades”, on on page 69.</p>	Perform Visual, Power On, Performance test blocks (see Table 2).
<p>Combining or Exchanging System Components</p>	Perform the System Test (see Table 2 and “System Test” on page 50).
<p>All other service events</p>	Perform Visual, Power On and Performance test blocks (see Table 2).

How to Carry Out the Test Blocks

Key to Table 2 P = Pass, F = Fail, X = test result value to be recorded.

Table 2: M2720A: Test and Inspection Matrix

Test Block	Test or Inspection to be Performed	Expected Test Results	What to Record on Service Record (Philips Personnel only)
Visual	Inspect the unit, transducers and cables for any damage. Are they free of damage?	If Yes, Visual test is passed.	V:P or V:F
Power On	Power on the unit. Does the self-test complete successfully?	If Yes, Power On test is passed.	PO:P or PO:F
Performance	Perform the parameter test with all parameters as described on page 44. Do these tests complete without errors?	If Yes, Performance Test is passed.	P:P or P:F
Safety (1)	Perform Safety Test: Protective Earth.	With mains cable: Maximum impedance = X1 ($\leq 100 \text{ m}\Omega$)	S(1):P/X1 or S(1):F/X1
Safety (2)	Perform Safety Test: Enclosure Leakage Current - Normal Condition.	With mains cable: Maximum leakage current = X2 ($\leq 100 \mu\text{A}$)	S(2):P/X2 or S(2):F/X2
Safety (3)	Perform Safety Test: Enclosure Leakage Current - Single Fault Condition - Open Supply.	With mains cable: Maximum leakage current = X3 ($\leq 500 \mu\text{A}$) (Note: maximum leakage current in the US: $300 \mu\text{A}$)	S(3):P/X3 or S(3):F/X3
Safety (4)	Perform Safety Test: Enclosure Leakage Current - Single Fault Condition - Open Earth.	With mains cable: Maximum leakage current = X4 ($\leq 500 \mu\text{A}$) (Note: maximum leakage current in the US: $300 \mu\text{A}$)	S(4):P/X4 or S(4):F/X4
System	Perform the system test according to IEC 60601-1-1, if applicable, after combining equipment to form a system.	See Safety Test (2) and Safety Test (3)	See Safety Test (2) and Safety Test (3)

Description of Applicable Safety Tests

Abbreviations

AP: Applied Parts

IUT: Instrument Under Test

GND: Ground

PE: Protective Earth

S(1): Protective Earth Test

Test to perform:

The protective earth test measures impedance of Protective Earth (PE) terminal to all exposed metal parts of Instrument under Test (IUT), which are connected to the Protective Earth (PE) for safety reasons. Normally it includes the wiring in the mains cable (max. 200 mOhm).

A test current of 25 Amps is applied for five to ten seconds. It is recommended to flex the main cable during the test to identify potential bad contact or damage to the earth wire.

Safety Test according to IEC 60601-1 (Clause 18).

Report the highest value.

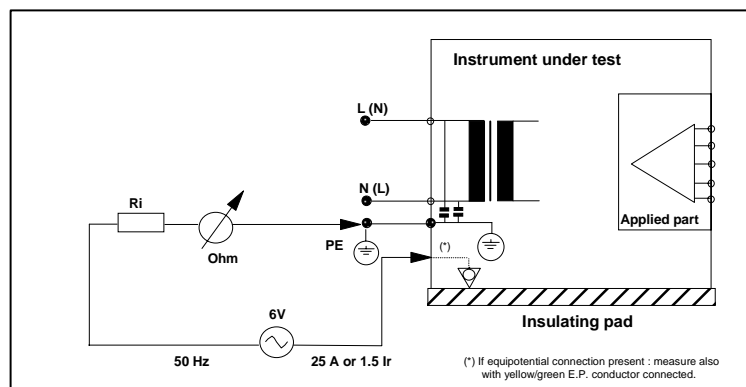

S(2): Enclosure Leakage Current Test - Normal Condition (NC)

Test to perform:

The enclosure leakage current: normal condition is applicable to Class 1 and 2 equipment, type B, BF, and CF Applied Parts. The test measures leakage current of exposed metal parts of the Instrument Under Test; it tests normal and reversed polarity.

For Type BF and CF Applied Parts the test measures AP/GND.

Safety Test according to IEC 60601-1 (Clause 19.4g).

Report the highest value.

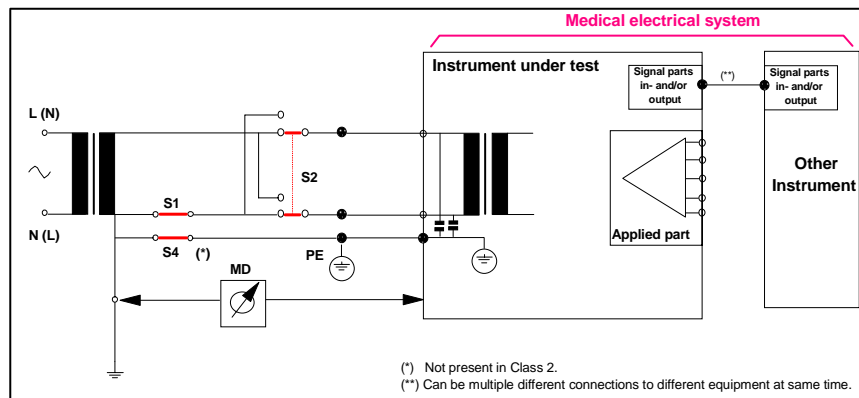

**S(3): Enclosure Leakage Current Test
- Single Fault Condition (SFC) Open Supply**

Test to perform:

The enclosure leakage current: single fault condition open supply is applicable to Class 1 and 2 equipment, type B, BF, and CF Applied Parts. The test measures leakage current of exposed metal parts of Instrument Under Test with one supply lead interrupted; it tests normal and reversed polarity.

For type BF and CF Applied Parts measures AP/GND.

Safety Test according IEC 60601-1 (Clause 19.4g).

Report the highest value.

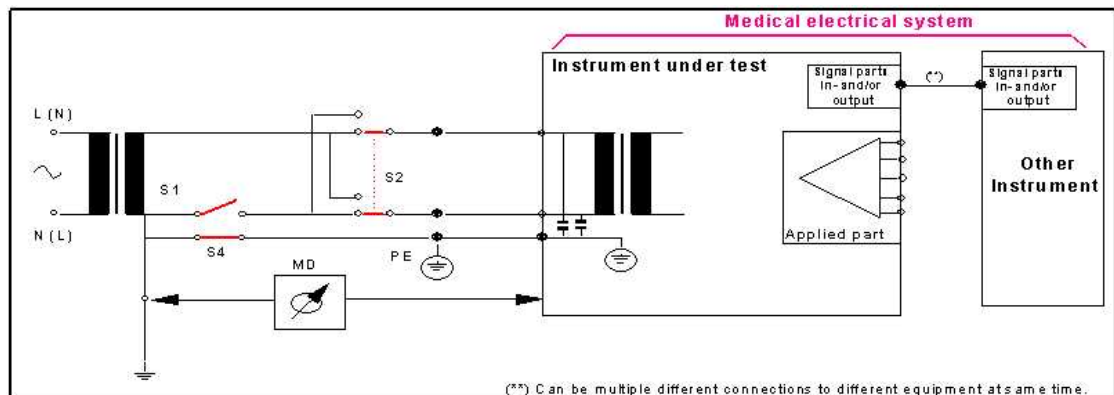

**S(4): Enclosure Leakage Current
- SFC Open Earth (Ground)**

Test to perform:

The enclosure leakage current: single fault condition open earth (ground) is applicable to Class 1 equipment, type B, BF and CF Applied Parts. The test measures leakage current of exposed metal parts of Instrument Under Test with Protective Earth open-circuit; it tests normal and reversed polarity.

For type BF and CF Applied Parts the test measures AP/GND.

Safety Test according IEC 60601-1 (Clause 19.4g).

Report the highest value.

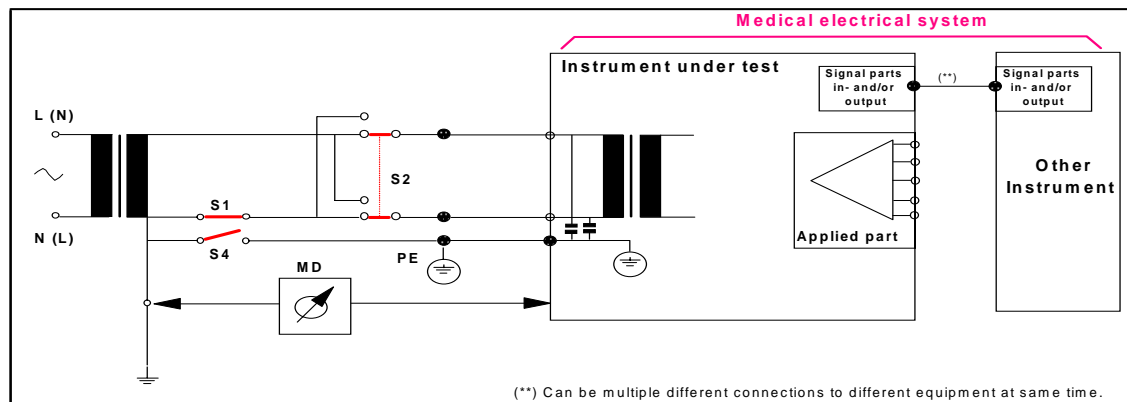

Instrument Safety Test

You must perform the instrument safety test every time you exchange, repair, upgrade or in any other way work on the power supply or the power inlet. You must test the system as a stand-alone system, and as a system in conjunction with the fetal monitor.

The instrument safety test is made up of four separate tests :

- Protective Earth Test
- Enclosure Leakage Current - Normal Condition
- Enclosure Leakage Current - Single Fault Condition
- Patient Leakage Current - Single Fault Condition

System Test

After mounting and setting up a system, perform system safety tests.

What is a Medical Electrical System?

A medical electrical system is a combination of at least one medical electrical device and other electrical equipment, interconnected by functional connection or use of a multiple portable socket-outlet.

General Requirements for a System

After installation or subsequent modification, a system must comply with the requirements of the system standard IEC/EN 60601-1-1. Compliance is checked by inspection, testing or analysis, as specified in the IEC 60601-1-1 or in this book.

Medical electrical equipment must comply with the requirements of the general standard IEC/EN 60601-1, its relevant particular standards and specific national deviations. Non-medical electrical equipment shall comply with IEC and ISO safety standards that are relevant to that equipment.

Relevant standards for some non-medical electrical equipment may have limits for enclosure leakage currents higher than required by the standard IEC 60601-1-1. These higher limits are acceptable only outside the patient environment. It is essential to reduce enclosure leakage currents when non-medical electrical equipment is to be used within the patient environment.

WARNING Do not connect any devices that are not supported as part of a system.

System Example

This illustration shows a system where both the medical electrical equipment and the non-medical electrical equipment is situated at the patient's bedside.

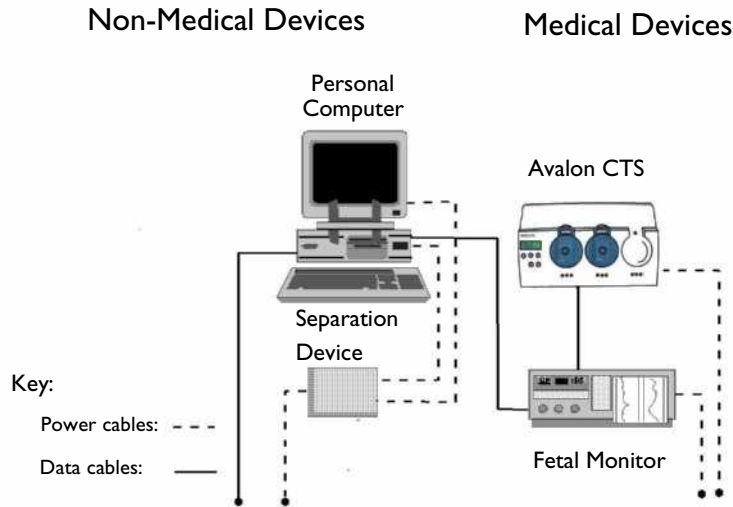

WARNING Any non-medical device placed and operated in the patient's vicinity (within a distance of 1.5m from the patient's bed) must be powered via an approved separation device (for example, an isolation transformer).

If the personal computer (or any other non-medical electrical device) is situated outside the medically used room, you must take measures to reduce leakage currents, such as providing an additional protective earth, a non-conducting enclosure, or a separation device.

We highly recommend using a separation device whenever you connect non-medical electrical equipment.

Regular Preventive Maintenance

The care and cleaning requirements that apply to the Avalon CTS and the monitoring accessories are described in the *Instructions for Use*. This section details the periodic maintenance recommended for the base station, transducers and accessories.

Mechanical Inspection

All rear panel connections must be tight. Check all exterior housings for cracks and damage. Check the condition of all external cables, especially for splits or cracks and signs of twisting. If serious damage is evident, the cable should be replaced immediately. Check that all mountings are correctly installed and secure. Refer to the instructions that accompany the relevant mounting solution. Check that the protective earth cable is properly and securely connected.

Visual Check

Ensure there are no cracks in the transducer housing. Make sure the battery drawer fits properly into the transducer housing, and that the sealing lip is in good condition. Inspect the LCD window, and if there is water or condensation behind the window, replace the transducer. On the ECG transducer, ensure that the adapter cable socket is not damaged.

Toco Ventilation/Belt Button

The Toco transducer requires air exchange for drift-free operation (see also the section “Underwater Monitoring” in the *Instructions for Use*). This is done by a ventilation membrane incorporated in the belt button. The effectiveness of the ventilation membrane should be checked at least once a year to ensure that free air exchange takes place. If the membrane is congested, the belt button must be exchanged (see the instruction sheet, “Removing and Replacing the Transducer Belt Button” that accompanies the belt button replacement kit, or see page 91 in this manual).

Testing the Ventilation Membrane

If you want to test the ventilation membrane in the belt button, you need the following:

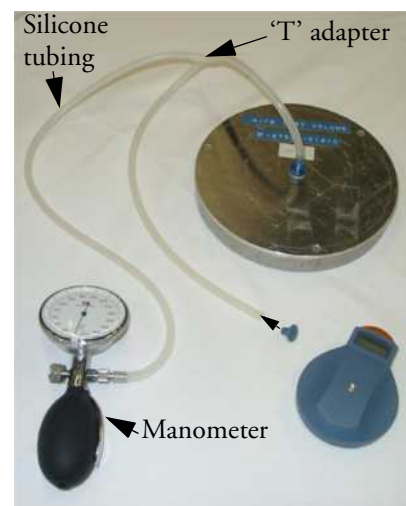

- Manometer.
 - Test volume chamber.
 - Three lengths of silicone tubing with a ‘T’ adapter.
- 1 Remove the belt button from the transducer using the special tool (see the instruction sheet “Removing and Replacing the Transducer Battery/Belt Button”).
 - 2 Connect the manometer to the volume chamber using two lengths of the silicone tubing and ‘T’ adapter as shown. Connect one end of the remaining length of silicone tubing to the ‘T’ adapter, and the other to the threaded end of the belt button.
 - 3 Apply pressure with the manometer (for example, 250 to 260 mmHg).
 - 4 Release the manometer valve. The pressure should fall rapidly, to indicate that the membrane is functioning correctly.

- 5 If the pressure does not fall rapidly, then the ventilation membrane is congested. Replace the belt button (see page 91, or the instruction sheet, “Removing and Replacing the Belt Button”, that accompanies the belt button replacement kit (part number M2720-64001) containing:
 - three replacement buttons.
 - a special tool to remove the button.
 - the instruction sheet.

Battery Check

If you suspect that battery performance is below normal expectations, and especially if the operating time consistently falls below 16 hours, charge the batteries.. Batteries that have a reduced capacity can still be used, even though they will have a shortened operating time, but a replacement should be considered as soon as possible.











When battery performance is suspect, even after a normal charge cycle, run the battery check. The Battery Check is a diagnostic procedure for determining the operating time of a fully charged battery. In normal operation, the battery will rarely approach a state of full discharge, typically only a small proportion of the total capacity will be used.

Even a battery with suspect performance will still have a relatively high capacity when it is freshly charged. **As a result, the test takes approximately eight hours. For the duration of the test, the Avalon CTS cannot be used.** To limit this down time, the test automatically stops if the batteries have reached the minimum operating time.

Removing a transducer from the base station during a battery check will start the transducer shut down process.

To run the battery check, all transducers must be inactive and at least one transducer must be docked in the base station. In the following example describes a battery check with two docked transducers, Transducer 1 and Transducer 2, in slots 1 and 2 respectively. Transducer 2 has a battery exhibiting reduced performance.

Starting the Battery Check

Step	Action	Display looks like...
1	Press the two arrow keys   simultaneously. The bed label blinks, the two-digit display goes blank.	
2	Press  twice to enter the 'A' settings. 'A' flashes in the display.	
3	Press  . 'A1' appears, and the '1' blinks.	
4	Press  twice to increment 'A' setting to 3.	
5	Press  . Base station display shows two segment bars for the duration of the check.	

Stopping the Battery Test





You can cancel the battery check at any stage by pressing  for more than one second, or by switching the base station to stand-by.

Stages of the Battery Check

The battery check has four stages:

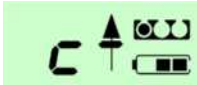
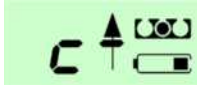
- 1 Battery charge cycle
- 2 Fast battery discharge
- 3 Battery capacity display

These stages are indicated by special patterns in the transducer LCD window.

Stage	Description	Transducer 1 display	Transducer 2 display
1	Battery charge cycle <ul style="list-style-type: none"> • The battery symbols of slots 1 and 2 blink, indicating that battery charging is in progress. • Transducers <ul style="list-style-type: none"> – remain unprogrammed – shut down if removed 		
		The right-hand horizontal segment bars of the two-digit numeric display wander up and down (from bottom up). This indicates that battery charging is in progress.	
2	Fast battery discharge <ul style="list-style-type: none"> • The battery is rapidly discharged. 		
		The right-hand horizontal segment bars of the two-digit numeric display wander up and down (from top down). This indicates that fast battery discharge is in progress.	
3	Battery capacity display <ul style="list-style-type: none"> • Transducer display shows the estimated operating time when: <ul style="list-style-type: none"> – the discharge time is over or – the battery is empty • In this example, the battery of Transducer 2 should be changed, as the estimated operating time is below the minimum 16 hours. 		
		The estimated operating time of the battery (in hours) alternates with the symbol 'H'.	

After the battery check has finished, the estimated operating time remains displayed until you press  for more than one second, or switch the base station to stand-by.

Reading Battery Check Data Using the Service Support Tool

The results of the last battery test performed are stored in the base station's EEPROM. There is no time stamp. This data can be read using the Service Support Tool, and this can be useful, for example, if the results of the battery check were not noted. Refer to the *Service Support Tool Help* for details.

Battery Exchange

If the battery requires replacement, use the battery kit (M2720-64001). This contains:

- a replacement battery already fitted into a replacement battery drawer
- a special tool for removing the battery drawer
- an instruction sheet

For details of how to replace the battery, see the Instruction Sheet "Removing and Replacing the Transducer Battery" that accompanies the battery replacement kit, or refer to page 75 in this guide.

Troubleshooting

A guide for recognizing system error messages and for troubleshooting problems you may encounter while using the system is given in the *Instructions for Use*. This chapter provides a guide for qualified service personnel for troubleshooting problems that cannot be resolved by the user.

CAUTION If the troubleshooting procedure requires you to disassemble the base station, be certain to follow the disassembly and reassembly procedures given in Chapter 4. Whenever parts are replaced in the system, be certain to verify the hardware and software compatibility of the repaired system.

System is Completely Inoperative

If the base station Power-On Light does not light when the base station is in stand-by or when switched on:

- Reset the system (see “System Reset” below).
- Check that the power cord is firmly connected to the base station.
- Check the condition of the power cable, and replace it if damaged, or if there are any defective connections.
- Check that the power cord is properly connected to the AC mains supply.
- Check the fuses, and replace if necessary. See “Changing Fuses” on page 22.

System Reset

Always reset the system as the first troubleshooting step. With the transducers docked in the appropriate slots, disconnect the power cord from the AC mains supply. Wait until the AC power LED is off, then reconnect the system to the AC mains supply. A persistent problem indicates a genuine malfunction.

If you think that the display information is suspicious, initiate the power-on self test by switching the base station to standby, and then switching it on again. All display elements of the transducer and base station should be displayed briefly before the normal registration process starts.

Common Problems

Reasons why the cordless transducers may not work properly are given below, along with suggested actions to take:

Possible Reasons	Action
Base station cannot tune into a free channel.	Check the antenna. Is it correctly and securely attached to the base station?
	Scan for RF interference (see “Scanning the Available Frequency Range” on page 64).
	Exclude frequency ranges with RF interference (see “Excluding Frequencies” on page 65).
	Fix the RF frequency used by the system (see “Base Station with Fixed Frequency” on page 65).
Out of available channels. For example, after excluding “problem” frequencies, only two channels are available, but you want to use three transducers.	Check if it is possible to get more free channels. As a workaround, you could alternate the use of one of the channels between US and ECG.
The transducer has a serial number of zero (not a valid number) and error E5 is displayed on the base station.	Assign a valid serial number to the transducer by using the Service Support Tool with a valid access code (see <i>Service Support Tool Help</i>).
Two transducers have the same serial number and error E5 is displayed on the base station.	Change the serial number of one of the transducers by using the Service Support Tool with a valid access code (see <i>Service Support Tool Help</i>), or replace one of the transducers with one from another base station.
Two or more transducers use the same frequency. Reasons: <ul style="list-style-type: none"> • There is more than one fixed frequency base station with the same channel spacing. OR <ul style="list-style-type: none"> • There are two or more transducers programmed with the same fixed frequency. 	<ul style="list-style-type: none"> • Change the base stations' base frequency and/or the channel spacing (see <i>Service Support Tool Help</i>). OR <ul style="list-style-type: none"> • Assign different fixed frequencies to each transducer (see <i>Service Support Tool Help</i>).
General incompatibility: for example, an ISM band transducer is being used with a WMTS band receiver.	Ensure hardware and software compatibility.
Communication error (always results in an inoperative transducer).	<p>Communication errors cannot be checked using the Service Tool.</p> <ol style="list-style-type: none"> 1. Check contacts (see page 62). 2. Reset the system (see page 57). 3. If reset fails, replace the transducer. 4. If problem persists, replace the base station.
Is the transmitter out of range?	Determine the effective operating range of the system in your particular environment, and inform the patient to stay within this area while monitoring takes place. See “Range Definition” on page 62.

Possible Reasons	Action
Is the antenna functioning properly?	Standard antenna: check the connection to the base station. Remote antenna: check the connection to the base station. Test the antenna system by bringing the transmitter close to the receiver. If the transmission is good, then the antenna system is not functioning properly. See also “Broadband Interference” on page 64.
Is the Avalon CTS mounted in an enclosed metal rack?	Try the base station outside of the rack. If there is a marked improvement, use the optional Antenna Extension Mounting kit (M1361A Option 1AA).
Is the patient near material that absorbs electromagnetic waves (for example, metal-reinforced concrete, elevator doors)?	If the problem relates to the construction of the building, consider an alternative location if this is practical.
Is the frequency range of the base station different from the transducer?	Ensure that both the base station and the transducers operate on the same frequencies. If necessary, change the frequencies. Refer to the <i>Service Support Tool Help</i> for details.
Are there other Avalon systems in the same location with the same frequency range?	In the case of multiple cordless/telemetry installations, allocate a unique fixed frequency to each system.
Is the transducer battery performance suspect?	Charge the battery. If battery performance is still not satisfactory after charging, carry out the battery check. (see page 43). If necessary, change the transducer battery (see page 75).
US acoustical signal is noisy, indicating interference.	To solve US interference problems: <ul style="list-style-type: none"> • In the case of a base station and transducers using automatic channel search, bring the transducer back to the base station and register it to a new frequency by docking it in an appropriate slot. • In the case of a base station with fixed frequencies, increase the channel spacing between the transducer slots (see “Base Station with Fixed Frequency” on page 65). • In the case of transducers with fixed frequencies, change the frequency and/or increase the frequency spacing between transducers (see “Transducers with Fixed Frequency” on page 66).

Troubleshooting a Cordless System: an Overview

Troubleshooting a cordless system presents some unique challenges. These arise from several assemblies acquiring signals, processing signals, and transmitting/receiving signals. Problems can result from hardware and communications failures, or can be RF-related.

In the case of a suspected malfunction it is important to first verify that the malfunction is a genuine failure. This can be checked by:

- Resetting the system
- Checking/cleaning the charge/communication contacts
- Checking the fetal monitor and antenna

Checking Contacts

If the transducer cannot be registered to the base station, or you suspect that the transducer is not behaving normally while it is docked, check that the spring-loaded charge/communication contacts are clean and free of dirt and ultrasound gel. Check that the springs function correctly by applying pressure with a finger on the contacts. The contacts should offer some resistance, deflect and return to their normal position; if they do not, then the top cover should be renewed (see “Replacing the Top Cover Assembly” on page 21).

Checking the Fetal Monitor

If parameter measurements are not possible, first check that the system is connected correctly to the fetal monitor using the appropriate interface cable as described in the technical specifications. Is the mode annotated on the recorder trace, or does it appear on the displays? If not, check that the interface cable is properly connected and that the cable locks are securely fastened. Also ensure that the fetal monitor’s recorder is switched on, and check, and if necessary replace, the power cord.

RF Problems

An RF problem can be summarized as a loss of monitoring capability due to signal corruption in the RF link (transmitter to antenna to receiver). A lack of parameter measurements, or the inability of the transducer to reach the registered, ready state may indicate an RF-related problem. A problem is likely to be an RF problem if it causes any of the following conditions:

- Weak or intermittent signals, or signal loss (see also “Area of Reach” on page 62).
- Interference (see also “RF Interference” on page 63).

The most likely reason for RF problems is a missing or inoperative antenna. Check that it is properly connected to the base station. If the antenna is properly connected, and the problem persists, then follow the RF troubleshooting operations in this chapter, starting at “Gathering Data” on page 61 through “Transducers with Fixed Frequency” on page 66.

Carrier to Noise Ratio

At any time, the performance of the RF reception of a cordless system is dependent on two factors:

- The signal strength of the desired or “carrier” signal.
- The power level of any background RF activity or “noise” at the same frequency.



In order for the cordless system to receive the RF signal without errors (corrupted or invalid data) the carrier power level must be significantly above the power level of any background noise. If data corruption occurs, it indicates that at that time the carrier to noise ratio (CNR) was too low.

When RF data corruption occurs, the most obvious symptoms are signal loss, degradation of the area of reach, or US noise.

The CNR can drop below the critical level for one or both of the following reasons:

- Low signal - the signal strength of the carrier is lower than expected.
- Interference - the background noise level at the receiver frequency is higher than expected.

Ultimately, all of the RF problems within your system occur because of these reasons.

Both of these problems can be identified by observing the signal loss indicator warning   on the base station, in addition to dropouts on the recorder traces (see also “Range Definition” on page 62). Refer to the *Service Support Tool Help* for more information about CNR.

Gathering Data

Gathering the information to troubleshoot a potential RF problem will probably account for around fifty percent of your job in determining if in fact you do have an RF problem. To gather data, you should:

- 1 Observe system performance
- 2 Question the user

Observe System Performance

While cordless monitoring offers many advantages, it can also provide challenges. The reliability and quality of the signal transmission through the air and hospital walls is governed by a number of variables which can be difficult to control. A cordless system cannot be as dependable as a hard-wired system that transmits its signal through a wire. This is because signals travelling through a wire are not subject to factors in the RF environment. The effect of problems in the RF environment on the cordless system ranges from momentary loss of the signal to complete inoperability, depending on the situation. While momentary signal loss is to be expected, frequent extended periods of signal loss need to be investigated.

Observe the system in operation. Does the system operation appear normal? If not, what seems abnormal about it? What warning indicators are on?

Question the User

Determining exactly what the user is complaining about can be difficult. RF signals are subject to interference and are inherently less reliable than signals passing through cables. Troubleshooting a cordless system is therefore more difficult than a wired system, and requires special equipment and techniques. The following checklist will assist you, when questioning the user, to gather data helpful for technical support:

- If you observed problems during system operation, confirm they are problems of which the user is complaining.
- Has the system always had these problems or are they a recent development?
- Is the symptom occurring on one channel, some channels, or all channels?
- Is the symptom occurring in a specific area or place?
- Is the symptom continuous or intermittent?
- How long does the symptom last?
- How often does the symptom appear?
- Does the symptom only occur at specific times?
- Does the symptom have “quiet” and “noisy” periods?

Area of Reach

The effective operating range, or the area of reach, of the system will vary depending on the geographical and constructional characteristics of the building where the system is installed. We recommend that you define the effective operating range prior to putting the system into operation.

If the area of reach is not sufficient using the standard antenna supplied with the system, there are a few things to consider initially:

- The placement of the antenna has an effect on the operating range. If it is located inside a metal cart or other RF-absorbing material, then place the antenna externally by using the Antenna Extension Mounting Kit (M1361A Option 1AA) to increase the range.
- Check the orientation of the antenna. In general, the antenna provides the greatest range when it is positioned vertically.
- If the area of reach is still insufficient, consider installing an antenna system.

Range Definition







You can define the area of reach by performing a walk-test, either carrying a fluid-filled bag with the transducers attached to it, or by wearing the transducers. The fluid-filled bag has the advantage that it can be placed in various positions (for example, in a bath tub) which would not be so practical for the tester. The area of reach can be determined by observing how far from the base station the transducers will still work normally allowing continuous monitoring. The testers can communicate with each other using appropriate communications equipment (for example, walkie-talkies).

There are two ways to define the area of reach:

- Watching the indicator/warning lamps on the base station.
- Watching the Received Signal Strength Indicator (RSSI) using a PC and the Service Support Tool. (Refer to the *Service Support Tool Help* for more details.)

Using the Base Station

How to proceed:

- 1 Connect the base station to the fetal monitor.
- 2 Switch on the fetal monitor's recorder.
- 3 Register the transducers to the base station, so that they are active. Wait until the slot's right-hand lamp  goes to green.
- 4 Take out the transducer and check for a good RF link. The lamp  should be continuously on.
- 5 Walk with the transducer to cover the area intended for monitoring.
- 6 If you see the signal loss warning lamps   blinking, then you are near the limit of the effective operating range of the system in the environment in question. Also, check for frequent mode annotations on the recorder trace. Loss of RF signal will show as dropouts on the recorded trace. This also indicates that you are close to the operating limit of the RF signal range.
- 7 Come back a short distance (say one meter/three feet at a time) until the signal loss warning lamps   stop blinking, the RF link lamp  is continuously on, and a reliable recorder trace without frequent dropouts is obtained.

- 8 Repeat to cover the whole area of intended operation. This is the limit of the range where the system can transmit and receive parameter measurements reliably.

Using the Service Support Tool

How to proceed:

- 1 Connect the base station to the fetal monitor.
- 2 Switch on the fetal monitor's recorder.
- 3 Connect the PC loaded with the Service Support Tool software to the base station using the PC interface cable (M1360-61675).
- 4 Register the transducers to the base station, so that they are active.
- 5 Use the Service Support Tool software to display the RSSI signals, for all slots, and additionally the amount of squelch noise for slots 1 and 2. Refer to the *Service Support Tool Help* for details.
- 6 Go to a different room within the intended operating area and place the fluid-filled bag there. You can place the bag in a bath tub to get a realistic indication of the area of reach when monitoring underwater (a metal bath tub and underwater monitoring both reduce the operating range).
- 7 Go back to the PC and check the RSSI signal displayed by the Service Support Tool. If the RSSI bar is yellow or green, then the signal quality is adequate. Poor quality, or loss of, RF signals will result in a low, red RSSI signal, together with a high amount of squelch. See the *Service Support Tool Help*. Check for frequent mode annotations on the recorder trace. Loss of RF signal will show as dropouts on the recorded trace. This indicates that you are close to the operating limit of the RF signal range.
- 8 Repeat to cover the whole area of intended operation. This is the limit of the range where the system can transmit and receive parameter measurements reliably.

RF Interference

You may encounter RF-related problems other than those associated with the area of reach. Problems concerning RF link stability are due to RF interference. There are two categories of interference:

- On-channel or narrowband interference
- Broadband interference

One-Channel or Narrowband Interference

This is defined as an interference source that occupies the same bandwidth as the transmitter and only interferes with one channel or two frequency adjacent channels.

It is likely that the channel is set to the same frequency as another telemetry unit, or there is interference from an external source, such as a broadcasting station. Be sure to check for adult and fetal telemetry channels. Also check for other radio devices such as walkie-talkies, paging systems, ambulance systems, and so forth.

If you encounter narrowband RF interference you can:

- Identify the “problem” frequencies or frequency ranges (see “Scanning the Available Frequency Range” on page 64).
- Exclude these frequencies or frequency ranges (see “Excluding Frequencies” on page 65).
- Set the base station or the transducers to fixed frequency operation (see page 65).

Broadband Interference

A broadband interference source occupies the bandwidth of many channels causing degradation of the carrier-to-noise ratio (CNR) on all of the telemetry channels for as long as it is present. This results in an increase in dropouts on all of the channels. The system has quiet and noisy periods. When the noise source is on, the system is noisy. When the noise source is off, the system performs well. To try to eliminate the problem:

- Troubleshoot the problem as it is occurring. Use the Service Support Tool to scan the RF environment for interference (refer to the *Service Support Tool Help* for details). Ask users to determine if there is a pattern, when the episodes occur, and how long they last. If there is a pattern (for example, every morning between 6 and 8 AM), try to predict when it will happen again, and prepare to troubleshoot.
- Locate where the interference signal is entering the system. If an antenna system is being used, remove branches from the antenna system to see when the interference quiets down. Remember that you will not be able to monitor patients that are being received by antennas that have been removed.
- Remember that interference sources can move, making troubleshooting a little more difficult. Work quickly!
- Solve the problem by trying to eliminate or repair the source. In the case of an antenna system, relocate or permanently remove the antenna where the signal is entering. Things to check for that cause broadband RF interference are other pieces of electrical equipment, especially RF devices using the same frequency range.

Guidelines for Channel/Frequency Configuration

- 1 Where there is no significant RF interference, no other telemetry devices and a small number of Avalon CTS systems (ten or less) are installed, then the standard configuration with automatic free channel search should be used.
- 2 If interference from other RF sources is encountered, then it may be appropriate to still use automatic free channel search, but excluding the offending frequencies (see “Excluding Frequencies” below), using the Service Support Tool.
- 3 If there are many telemetry devices and/or multiple Avalon CTS installations in the hospital, we recommend that an RF plan is implemented, with different frequency ranges allocated to different types of telemetry. In this case, the base station should be set to fixed frequency operation (see “Base Station with Fixed Frequency” on page 65), in conjunction with excluded frequency ranges.
- 4 If there are only a small number of available frequency channels, consider using fixed frequency transducers (see “Transducers with Fixed Frequency” on page 66). If dedicated frequencies are required, use fixed frequency transducers.

Scanning the Available Frequency Range

If interference is evident or suspected the first step is to use the Service Support Tool to perform a scan of the available frequency range to identify interferers and locate occupied frequency ranges. This informs you which frequencies you may need to exclude. To do this you need:

- An industry standard PC with the Service Support Tool software installed (supplied on Documentation CD-ROM M1350-9150T)
- PC interface cable for the Service Support Tool (M1360-61675)

Refer to the *Service Support Tool Help* for details.

Excluding Frequencies

Having established the occupied frequency ranges by scanning the available frequency range (see above), you can exclude up to four frequency ranges by using a PC installed with the Service Support Tool.

Refer to the *Service Support Tool Help* for details.

Base Station with Fixed Frequency

There are instances when free channel selection is not desired, and the setting of fixed frequency for the base station is preferable or necessary. For multiple cordless/telemetry installations in the same hospital, especially when connected to an antenna system, the hospital should implement an RF plan. Each system (adult telemetry, fetal telemetry, Avalon cordless), should have a fixed frequency reserved for it, and this should be documented in a suitable way (for example, on an RF chart).

The setting of fixed frequencies is done using the Service Support Tool. Refer to the *Service Support Tool Help* for details.

The frequency of a slot is separated from that of another slot from the same base station by channel spacing. The base station is shipped with a default channel spacing appropriate for the country in question, and normally this requires no adjustment.

If there are transducers working close to each other from the same base station and the transducers are interfering with each other (exhibited, for example, by a noise on the ultrasound channel), you can make the channel spacing wider (**only** after consulting Philips Support). You can do this by changing the F-settings using the Service Support Tool (refer to the *Service Support Tool Help*), or manually using the configuration keys on the base station (refer to page 66).

The first slot allocates the base fixed frequency to its transducer. The frequency allocated by the second slot to its transducer is the base frequency plus the channel spacing (whether default or user-selected). The frequency allocated by the third slot is the frequency of the second slot plus the channel spacing.

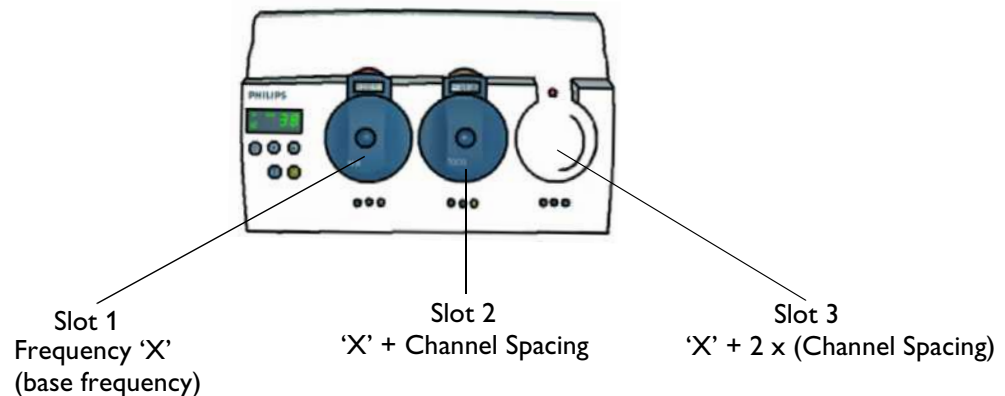

Due to this way of allocating the frequencies to the second and third slots, avoid setting the base fixed frequency for the first transducer slot at the very end of the available frequency range for your country, otherwise it will not be possible to allocate a frequency channel to slots 2 and 3.

Transducers with Fixed Frequency

Sometimes it is preferable or necessary to set fixed frequencies for the transducers. In this case, the base station is set to automatic channel search. When a transducer is docked in a slot, the base station recognizes that the transducer is set to a fixed frequency, and allocates that frequency to the transducer.

The setting of fixed frequencies is done using the Service Support Tool (**only** after consulting Philips Support). Refer to the *Service Support Tool Help* for details.

Transducers with fixed frequencies have the following advantages:

- They are particularly suitable for use with antenna systems.
- They are particularly suitable in large installations, where you can avoid interference problems between the large number of telemetry systems or other RF interference sources.
- They make it easier to prevent the Avalon CTS system from interfering with other RF devices.
- They make it easier to interchange transducers between different base stations.

Do not assign the same frequency to more than one transducer.

Note that in case of repair, transducers with fixed frequencies cannot be exchanged so easily.

Transducers for Japan

Transducers for Japan must use fixed frequencies. They are initially shipped from the factory with no frequencies assigned to them. During installation, they are initialized, and their frequencies are set. This can only be done once, and if it needs to be done again, an access code must be obtained from the factory. Refer to the *Service Support Tool Help* for details.

Multi-Region Base Station

The Multi-Region base station is a special version of the the ISM band base station, using only restricted RF channels within the broader ISM band.

Delivery Status

The base station receiver is 'disabled' at the factory before shipment. If you dock transducers in a base station in this disabled state, the base station will not assign any frequencies to them. The transducer display will show a blinking  warning message.

Installation

You need to enable the base station during installation using the Service Support Tool.

Set the correct frequency channels using the Service Support Tool (see the *Service Support Tool Help* for details).

Choose the appropriate country from the drop-down menu of available (non-standard) countries. As you do this, the Service Support Tool automatically determines the relevant frequency ranges to allocate and exclude.

Refer to the *Service Support Tool Help* for details.

- **Only for Norway:**
The default frequency channels are the ten country-specific frequency channels approved for use by the local authorities. By choosing Norway from the drop-down country menu, the Service Support Tool automatically determines the relevant frequency ranges to allocate and exclude.
- If you cannot use these default frequency channels, you need to apply for specific fixed frequencies within the full ISM band frequency range from the local authorities. Once the frequencies are approved, you need to set the base station to the full ISM band frequency range, and then to manually set the specific approved fixed frequencies to the transducers within the ISM band.

Refer to the *Service Support Tool Help* for details.

NOTE You can only set the country once. If you need to reset the country code, you need an access code. Please contact Philips Support.

Ensure that the frequency channels you set comply with any local regulations, and that these channels do not cause interference or conflict with any other telemetry devices.

Testing Transducers

This section shows you how to carry out an electrical check on the transducers. Details of the visual inspection are given in Chapter 6.

Ultrasound Transducer Electrical Check

CAUTION Use of ultrasound gel that is not approved by Philips may reduce signal quality and may damage the transducer. This type of damage is not covered by warranty.

- 1 Register the transducer to the base station following the red color coding, so that it displays a bed label and has an active RF link (see the *Instructions for Use* for details).
- 2 Turn the fetal monitor's loudspeaker volume up to an audible level.
- 3 The ultrasound transducer contains seven piezoelectric crystals. Basic functioning of each can be verified by holding a flat bottomed pencil or similar above each crystal and moving it up and down as shown.

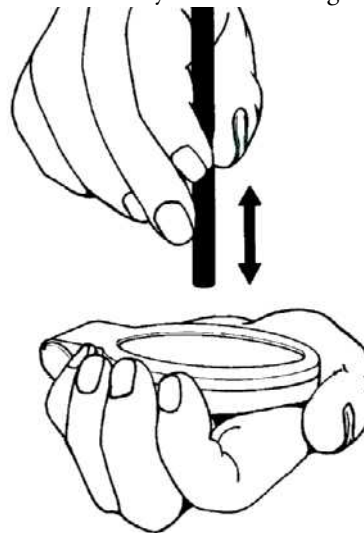

psm18sca.tif

Figure 4 Testing an Ultrasound Transducer Using a Pencil

A sound should be heard for each crystal tested. The pencil should be held two to three centimeters from the transducer surface when the test is carried out.

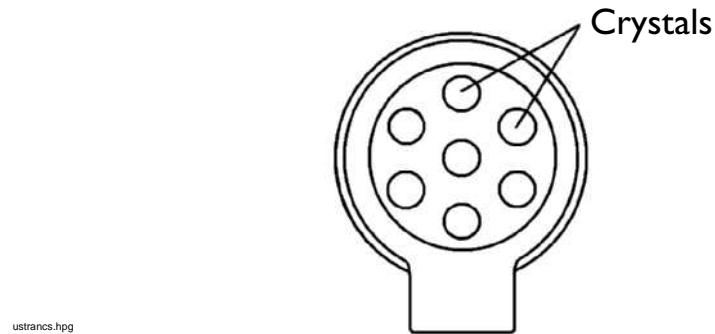

Figure 5 Position of Crystals in an Ultrasound Transducer

- 4 A sound should also be heard when the transducer is moved back and forth over a solid surface, or the hand as shown below.

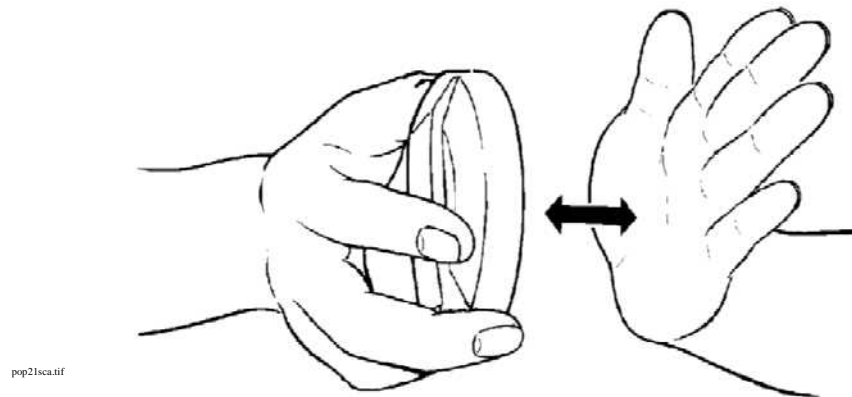

Figure 6 Checking an Ultrasound Transducer

If the test results are not as outlined above, repeat the tests with another transducer. If this does not solve the problem:

- Check that the base station is properly connected to the fetal monitor.
- There is likely to be a RF-related problem. Check for frequent mode annotations on the fetal monitor's recorder to confirm this. Refer to the information on RF troubleshooting in this chapter, and to the chapter "Troubleshooting" in the *Instructions for Use*.

If the problem persists, replace the transducer.

The transducers are sealed and are **NOT** repairable.

TOCO Transducer Electrical Check

- 1 Register the transducer to the base station following the brown color coding, so that it displays a bed label and has an active RF link (see the *Instructions for Use* for details).

Ensure that:

- the Toco display shows 20 on the fetal monitor.
- when the recorder is switched on, the date, time, mode and paper speed are printed on the recorder trace.

- 2 Press the transducer's Toco sensor firmly and look for a deflection on the display and recorder. The external Toco display maximum is 127 units.
- 3 Lay the transducer face up on a hard, flat surface for a few seconds, so that the belt button and the take-out aid end of the transducer make contact with the surface (see Figure 7 on page 69).
- 4 Press the Toco Baseline Key to re-adjust the Toco display to 20.
- 5 Turn the transducer over so that the Toco sensor is resting on the flat surface. The transducer will always adopt the same, slightly inclined position, with the take-out aid end of the transducer also resting on the surface (see Figure 7).

You should see a marked increase in the value of the Toco reading in the Toco display.

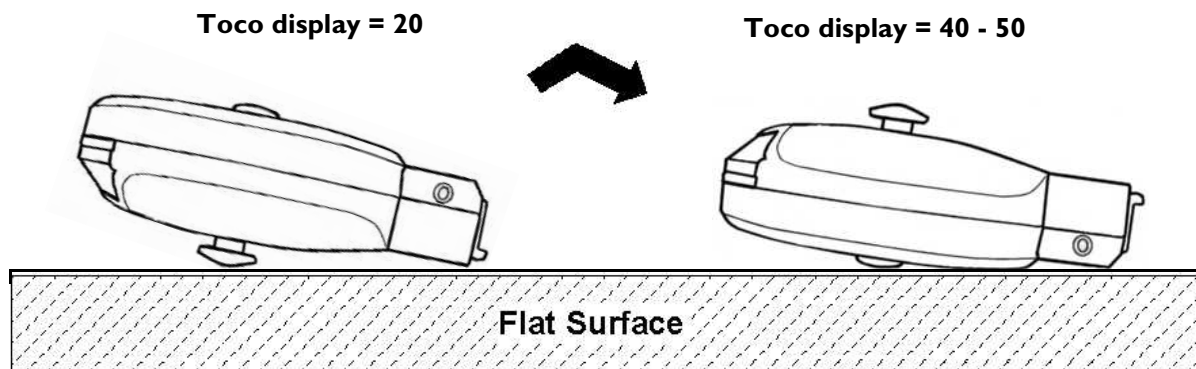

Figure 7 Checking a Toco Transducer

If the test results are not as outlined above, repeat the test with another Toco transducer. If this does not solve the problem:

- Check that the base station is properly connected to the fetal monitor.
- There is likely to be an RF-related problem. Check for frequent mode annotations on the fetal monitor's recorder to confirm this. Refer to the information on RF troubleshooting in this chapter, and to the chapter "Troubleshooting" in the *Instructions for Use*.

If the problem persists, replace the transducer.

The transducers are sealed and are NOT repairable.

ECG Transducer Electrical Check

Carry out the electrical check on the ECG transducer in both DECG and MECG mode.

In DECG Mode

- 1 Ensure that the ECG transducer is registered to the base station, is showing a bed label and has a good RF link to the base station.
- 2 Attach the DECG adapter cable M1362B to the red color-coded socket on the transducer.
- 3 Ensure that the Cardio 1/Combi channel display on the fetal monitor shows **nop** with the adapter cable M1362B attached.
- 4 Take a new (sterile) Fetal Scalp Electrode, and connect it to the DECG adapter cable.

5 *EITHER*

Make a short between the spiral electrode and the reference electrode with your fingers (it is best to wet your fingers first).

CAUTION The tip of the spiral electrode is sharp. Take care not to injure your fingers.

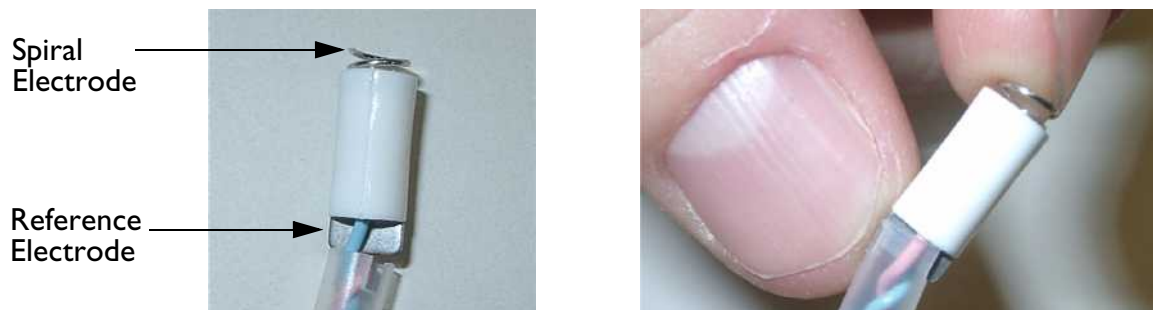

OR

Cut off the plastic tip of the fetal scalp electrode (containing the spiral and reference electrodes) from the end of the wires. Strip the insulation from the end of the wires, and connect them to a patient simulator.

Note—We do not recommend the use of a specific patient simulator. The use of a patient simulator does not allow checking the specification of the ECG-Functionality; it allows only a check of general function.

Result: **nop** should disappear.

If the test results are not as outlined above, repeat the test with another ECG transducer. If this does not solve the problem consider the following:

- Check that the base station is properly connected to the fetal monitor.
- There is likely to be an RF-related problem. Check for frequent mode annotations on the fetal monitor's recorder to confirm this. Refer to the information on RF troubleshooting in this chapter, and to the chapter "Troubleshooting" in the *Instructions for Use*.
- If **nop** is still displayed, the DECG adapter cable may be defective. Replace the adapter cable.

If the problem persists, replace the transducer.

The transducers are sealed and are **NOT** repairable.

In MECG Mode

- 1 Ensure that the ECG transducer is registered to the base station, is showing a bed label and has a good RF link to the base station.
- 2 Attach the MECG adapter cable M1363A to the red color-coded socket on the transducer.
- 3 MECG values are displayed on the maternal LCD display (according to fetal monitor specification) or annotated on the recorder strip.

4 *EITHER*

Attach electrodes to the M1363A adapter cable, and apply the electrodes to the skin (for example on the wrists).

OR

Attach the M1363A adapter cable to a patient simulator.

Note—We do not recommend the use of a specific patient simulator. The use of a patient simulator does not allow checking the specification of the ECG-Functionality; it allows only a check of general function.

Result: You should see MECG values displayed on the maternal LCD display or annotated on the recorder trace.

If the test results are not as outlined above, repeat the test with another ECG transducer. If this does not solve the problem:

- The MECG adapter cable may be defective. Replace the adapter cable, and repeat the test.
- Check that the base station is properly connected to the fetal monitor.
- There is likely to be an RF-related problem. Check for frequent mode annotations on the fetal monitor's recorder to confirm this. Refer to the information on RF troubleshooting in this chapter, and to the chapter "Troubleshooting" in the *Instructions for Use*.

If the problem persists, replace the transducer.

The transducers are sealed and are NOT repairable.

Troubleshooting the Top Cover

Note that malfunction of the top cover can be due to MIF board failures. In this case, repair is effected by exchanging the base station.

If after opening the top cover, or following a repair, the display, all lamps, and all function buttons fail to work, check the ribbon cable connection to the MIF board.

The top cover contains the following items:

- Charge/communication contacts (see "Checking Contacts" on page 60)
- Function buttons
- Display/window
- LEDs
- Magnets

Function Buttons

If any of the buttons fail to function, reset the system (see "System Reset" on page 57). If an individual button fails to work, try to solve the problem by renewing the top cover (see "Removing the Top Cover Assembly" on page 20 and "Replacing the Top Cover Assembly" on page 21). If all the function buttons fail to work, then this is likely to be a MIF board malfunction, a repair being effected by exchanging the base station.

Display/Window

If the base station display does not function or you suspect that it is not working normally, reset the system (see “System Reset” on page 57), and check the lamps during the lamp-test phase of the self-test. Look for:

- missing segments of the two-digit display.
- defective lamps.
- LED segments of the two-digit display that are flicker or are darker or lighter than normal (indicates MIF board malfunction, and hence base station exchange).

If the problem persists, replace the top cover, or exchange the base station, as appropriate. If the display window breaks, or is scratched and no longer readable, renew the top cover (see “Removing the Top Cover Assembly” on page 20 and “Replacing the Top Cover Assembly” on page 21).

LEDs

If any of the LEDs fail to light when they should, reset the system (see “System Reset” on page 57). If the problem persists, renew the top cover assembly (see “Removing the Top Cover Assembly” on page 20 and “Replacing the Top Cover Assembly” on page 21).

Magnets

If you see something unusual in the transducer’s LCD, or if you pick up and gently shake the base station and you can hear something moving inside, then it is likely that one or more of the three magnets has been dislodged. To investigate further:

- 1 Remove the top cover assembly (see “Removing the Top Cover Assembly” on page 20).
- 2 Try to refit the magnet - it should snap back into place.
- 3 If the magnet does not snap into place, then the plastic lugs that hold the magnet are probably broken or damaged. If this is the case, renew the top cover assembly (see “Replacing the Top Cover Assembly” on page 21).

Factory Information Code Log

All detected hardware and software internal errors generated by the base station and the transducers are logged in an internal log file residing in the EEPROM. The errors are mapped to a two-digit hexadecimal Factory Information Code (FIC). The FIC is stored in the EEPROM, with the oldest code at the top of the list and the newest at the bottom. The contents of the FIC log require no interpretation. The log file can only be read using the Service Support Tool via the service port. The log can be saved to a file and the file returned to the factory for debugging (see the *Service Support Tool Help* for details). The log can only be cleared manually by using the keys on the base station (see Chapter 8, “Changing Settings”).

Changing Settings

There are four classes of settings for individually configuring the Avalon CTS:

- Bed Label setting (refer to *Instructions for Use*)
- C = Configuration settings (refer to *Instructions for Use*)
- F = Function settings
- A = Action settings

The C and F settings can be set:

- using a PC with the Service Support Tool installed. This is the recommended method.
- manually, using the keys on the base station.

The A settings can only be set manually, using the keys on the base station.

Configuration Settings















The *Instructions for Use* describes how to manually change the theft protection level (C1), theft protection alert volume (C2), key click volume (C3), audible alert volume (C4) and acoustical alarmdefault (C5).

Function Settings

To change the function settings manually, follow the step-by-step instructions.







Bed Label Appearance









The bed label can be set to appear as two-digit numeric characters between 00 and 99 (factory default), or as a mix of one alphabetic and one numeric character (for example, A1, B5, C9 and so forth). To change the way the bed label is displayed:

Step	Action	Display looks like...
1	Press the two arrow keys   simultaneously. The bed label blinks, the two-digit display goes blank.	
2	Press  three times to enter the 'F' settings. 'F' flashes in the display.	
3	Press  . 'F1' appears, and the '1' blinks.	
4	Press  again. Two-digit display shows the current setting (1.0=numeric characters only, 1.1=mixed alphabetic and numeric characters)	
5	Press  or  to change the setting.	
6	Press  to accept the new setting and return to normal operation.	

Enabling/Disabling Fixed Frequency

The Service Support Tool is required to set the base frequency. Fixed frequency selection can be enabled on the base station, as follows.











Step	Action	Display looks like...
1	Press the two arrow keys   simultaneously. The bed label blinks, the two-digit display goes blank.	
2	Press  three times to enter the 'F' settings. 'F' flashes in the display.	
3	Press  . 'F1' appears, and the '1' blinks.	





Step	Action	Display looks like...
4	Press  once to increment 'F' setting to 2.	
5	Press  . Two-digit display shows the current setting (2.0=automatic channel search, 2.1=fixed frequency)	
6	Press  or  to change the setting.	
7	Press  to accept the new setting and return to normal operation.	

Selecting the Channel Frequency Spacing

See also page 54. Consult Philips Support before changing the channel frequency spacing.

The Service Support Tool is required to set the base frequency. The channel frequency spacing can be set using the Service Support Tool (see *Service Support Tool Help* for details), or on the base station as follows:















Step	Action	Display looks like...
1	Press the two arrow keys   simultaneously. The bed label blinks, the two-digit display goes blank.	
2	Press  three times to enter the 'F' settings. 'F' flashes in the display.	
3	Press  . 'F1' appears, and the '1' blinks.	
4	Press  twice to increment 'F' setting to 3.	
5	Press  . Two-digit display shows the current setting. (Channel spacing can be set between 0 and 8 inclusive.) 3.0 = default spacing 3.1 = 1 x 12.5 kHz = 12.5 kHz 3.2 = 2 x 12.5 kHz = 25 kHz 3.n = n x 12.5 kHz and so forth	

Step	Action	Display looks like...
6	Press  or  to change the setting for the spacing.	
7	Press  to accept the new setting and return to normal operation.	





Action Settings







The action settings can be changed **only** on the base station. To change the action settings, follow the step-by-step instructions.

Displaying the Software Revision











Step	Action	Base station display looks like...		
1	Press the two arrow keys   simultaneously. The bed label blinks, the two-digit display goes blank.			
2	Press  twice to enter the 'A' settings. 'A' flashes in the display.			
3	Press  . 'A1' appears, and the '1' blinks.			
4	Press  once to increment 'A' setting to 2.			
5	Press  . Two-digit display shows the software revision, in the format A.XX.XX, as a sequence. For example, revision A.01.00 is shown in the following way. This cycles for 30 seconds before the display reverts back to normal.	Transducer display (if docked)...		
		1		Base station display shows sequence
		2		
		3		

Clearing the Factory Information Code (FIC) Log

Step	Action	Display looks like...
1	Press the two arrow keys   simultaneously. The bed label blinks, the two-digit display goes blank.	
2	Press  twice to enter the 'A' settings. 'A' flashes in the display.	

Step	Action	Display looks like...
3	Press  . 'A1' appears, and the '1' blinks.	
4	Press  three times to increment 'A' setting to 4.	
5	Press  . The FIC log is cleared, and the display reverts to normal.	

Starting the Battery Check

Step	Action	Display looks like...
1	Press the two arrow keys   simultaneously. The bed label blinks, the two-digit display goes blank.	
2	Press  twice to enter the 'A' settings. 'A' flashes in the display.	
3	Press  . 'A1' appears, and the '1' blinks.	
4	Press  twice to increment 'A' setting to 3.	
5	Press  . Base station display shows two segment bars for the duration of the check.	

Upgrades

The software of the base station and the transducers can be upgraded by a software download from a PC. The base station has a service socket for connection to a PC's standard RS232 serial port. You will need:

- Industry standard PC
- Service Support Tool (on Fetal Monitoring Documentation CD-ROM*)
- PC interface cable for the Service Support Tool (M1360-61675)
- Downloadable software upgrade file (instructions for the download procedure come with the software package. Contact Philips Support for further details).

Refer to the *Service Support Tool Help* for details of the upgrade procedure.

For tests to perform after upgrading, see “When to Perform Safety Tests” on page 46.

*. Please refer to your local Response Center for the part number.

Specifications

Specifications for the accuracy of heart rate measurements are given in the *Instructions for Use* of the fetal monitor.

General

Environmental Specifications (Transducers and Base Station)		
Temperature Range	Charging	0°C to 45°C (32°F to 113°F)
	Operating	0°C to 45°C (32°F to 113°F)
	Storage (without battery)	-20°C to +60°C (-4°F to 158°F)
	Storage with battery	Depends on initial charge level and temperature (storage time decreases significantly at high (> 45°C/113°F) temperatures)
Humidity Range	Operating	5% to 95% relative humidity @ 40°C/104°F
	Storage	5% to 85% relative humidity @ 50°C/122°F
Altitude Range	Operating	≤ 3000m/9800 ft.
	Storage	≤ 15000m/49000 ft.

Base Station

Base Station Specifications		
Receiver Unit		
Power	Supply Voltages	100 VAC to 240 VAC ± 10%
	Supply Frequency Range	50 Hz to 60 Hz
	Consumption	15 VA
Type of Protection Against Electrical Shock	Class I equipment	
Dimensions and Weight	Size mm/(in): width x depth x height	350 x 240 x 75 (13.8 x 9.5 x 3.0 in)
	Weight	2.5kg/5.5 lbs without transducers
Input Sensitivity	Input Sensitivity	-110 dBm @ 30dB Signal-to-Noise Ratio
Image Rejection	Image Rejection	> 80dB
Ranges	Frequency Range	See Frequency options
	Receiving Range (line of sight)	approximately 100m/300 ft.

Base Station Specifications		
Antenna	Input Impedance	50 Ω
Water Ingress Protection Code	IP X1 (protection only against vertically falling water drops)	
Monitor Interface		
Toco Output	Accuracy	$\pm 0,5\%$ per 100 mmHg (not including transmitter)
	Offset	± 5 Units (not including transmitter)
	Range	0 to 4V
Voltage Range	US Voltage range	4mVpp to 4Vpp
	ECG Voltage range	0.1Vpp to 4Vpp

Transducers

Transducer Specifications		
General		
Shock Resistance	Withstands a 1m drop to concrete surface with possible cosmetic damage	
Usability Underwater	0.5m/1.64 ft	
Water Ingress Protection Code	IP 68 (0.5m/1.64 ft immersion for 5 hours)	
Dimensions and Weight	Size (diameter)	< 10 cm/3.94 in
	Weight	< 140 g/4.8 oz.
Battery	Type	Lithium Ion
	Capacity	> 16 hours (> 700mAh)
	Life	> 500 charge/discharge cycles (with new battery, at 25°C/77°F)
	Transducer Storage Time	≥ 1 year at 25°C/77°F (battery full)
		≥ 1 month at 25°C/77°F (battery empty)
	Recharging Time	100% charged < 3h
		66% charged ≤ 1 h
	Forced discharge current	approx. 45mA
Discharge leakage current in shutdown @ Vbat = 3V, 25°C	20 μ A (typical), 70 μ A (max)	
Degree of Protection Against Electrical Shock	Type CF	
RF Unit		
Nominal RF Output Power	-12 dBm \pm 6 dB ERP	
Carrier Frequency Range	See Frequency Bands	
Minimum Frequency Band Span Per Option	10 MHz	
Channel spacing	25kHz or 12.5kHz	

Transducer Specifications		
Modulation type	Analog	frequency modulation (frequency range depends on frontend board)
	Digital	FSK 1.6kHz and 2.4kHz

Frequency Bands

Frequency Bands	
Frequency Range	Major countries
420 to 430 MHz, of which the following sub-ranges are used: <ul style="list-style-type: none"> – Band 1: 420.0625 to 421.0125 MHz – Band 2: 424.5000 to 425.9500 MHz – Band 3: 429.2625 to 429.7125 MHz 	Japan
433.0500 to 434.7900 MHz	Most European countries, Singapore (ISM band)
441.7500 to 441.9750 MHz	Norway This is the default ten-channel band within the ISM band approved by the local authorities. Other channels (for transducers using specific fixed frequencies within the ISM band) may additionally be approved for use. Contact Philips Support for further information.
608.0125 to 613.9875 MHz	US medical telemetry (WMTS) band, Canada, Australia and New Zealand

Frontends

Frontends			
US Frontend	US Intensity	Peak-negative acoustic pressure	$p_- = (27.4 \pm 4.6) \text{ kPa}$
		Output beam intensity (= temporal average power/area)	$I_{ob} = (2.64 \pm 0.83) \text{ mW/cm}^2$
		Spatial-peak temporal average intensity	$I_{spta} = (7.0 \pm 2.3) \text{ mW/cm}^2$
	US Frequency		1 MHz
	US Signal range		3.5 μVpp to 350 μVpp @ 200 Hz
	US Burst Repetition Rate		3.2 kHz
	US LF Frequency Passband		110 to 450 Hz \pm 20%
	FMP Signal Range (rti)		200 μVpp to 40 mVpp
FMP Frequency Passband		10 to 90 Hz \pm 20%	
TOCO Frontend	Signal Range		0 to 127 units
	Offset Compensation (offset adjust at the fetal monitor)		+100 to -200 units
	Measurement Range		-100 to 300 units
	Resolution		0.25 units
	Sensitivity		2.5g/unit (0.1 oz/unit)
	Baseline Drift due to Temperature Changes		
			5 units/min/ $^{\circ}\text{C}$ (underwater)

Frontends		
ECG Frontend	Type	Two Lead ECG
	Input Impedance	> 10M Ω @ 35 Hz
	CMRR	> 110 dB (with 51.1 kW 47nF imbalance @ line frequency)
	Noise	< 4 μ Vp @ 25 k Ω input impedance
	Contact Potential	\pm 500 mV
	Inop Amplitude at open LA/ RA contacts	60 to 90 mV
	Inop Auxiliary Current	< 100 nA
	Input Voltage Range ECG	20 μ Vpp to 4 mVpp (66dB)
	Input DC tolerance	\pm 400 mV
	Dielectric Strength	1500 Vrms
	Frequency passband	0.7 to 80 Hz
	Defibrillator Protection	None
	ESU Protection	None
AUX Frontend	Communication Protocol	Serial, 1 start bit, 1 stop bit, 8 data bits, no parity
	Serial Communication Voltage Levels	Unipolar 3 V Receive: mark = 0V, space = ~3 V Transmit: mark = 0 V, space = high impedance (requires pull up resistor)
	Communication Speed	fixed 1200 Baud
	Max. Output Current for External Devices	100 mA electronically limited
	Output Voltage for External Devices	3 V \pm 2%

Cables

Cables		
Type	Part Number	Length
Monitor interface cable	M2720-61603	1.6 m/5.2 ft approx.
Service Tool cable	M1360-61675	\leq 3.0 m/9.8 ft
Power cable	Country dependent	\leq 2.4 m/7.9 ft

Electromagnetic Compatibility (EMC) Specifications

The Electromagnetic Compatibility (EMC) specifications in this chapter supplement those given in the *Instructions for Use*.

Emissions and Immunity

The product is designed and evaluated to comply with the emissions and immunity requirements of international and national EMC standards.

The EMC standards state that manufacturers of patient-coupled equipment must specify immunity levels for their systems. See Tables 1, 2 and 3 for this detailed immunity information. See Table 4 for recommended minimum separation distances between portable and mobile communications equipment and the product.

Immunity is defined in the standard as the ability of a system to perform without degradation in the presence of an electromagnetic disturbance.

Caution should be exercised in comparing immunity levels between different devices. The criteria used for degradation are not always specified by the standard and can therefore vary with the manufacturer.

Electromagnetic Immunity

The M2720A (referred to in the following sections as the ‘device’) is suitable for use in the specified electromagnetic environment. The user must ensure that it is used in the appropriate environment as described below.

Table 1

Immunity Test	IEC 60601-1-2 Test Level	Compliance Level	Electromagnetic Environment Guidance
Electrostatic discharge (ESD) IEC 61000-4-2	± 6 kV contact ± 8kV air	± 6 kV contact ± 8kV air	Floors should be wood, concrete, or ceramic tile. If floors are covered with synthetic material, the relative humidity should be at least 30%.
Electrical fast transient/burst IEC 61000-4-4	± 2 kV for power supply lines ± 1 kV for input/output lines	± 2 kV for power supply lines ± 1 kV for input/output lines	Mains power quality should be that of a typical commercial and/or hospital environment
Surge IEC 61000-4-5	± 1 kV differential mode ± 2 kV common mode	± 1 kV differential mode ± 2 kV common mode	Mains power quality should be that of a typical commercial and/or hospital environment
Voltage dips, short interruptions and voltage variations on power supply input lines IEC 61000-4-11	<5% U_T (> 95% dip in U_T) for 0.5 cycles 40% U_T (60% dip in U_T) for 5 cycles 70% U_T (30% dip in U_T) for 25 cycles < 5% U_T (> 95% dip in U_T) for 5 sec	0% U_T (100% dip in U_T) for 0.5 cycles 40% U_T (60% dip in U_T) for 5 cycles 70% U_T (30% dip in U_T) for 25 cycles 0% U_T (100% dip in U_T) for 5 sec	Mains power quality should be that of a typical commercial and/or hospital environment. If the user of the device requires continued operation during power mains interruptions, it is recommended that the device is powered from an uninterruptible power supply.
Power frequency (50/60 Hz) magnetic field IEC 61000-4-8	3 A/m	3 A/m	Power frequency magnetic fields should be at levels characteristic of a typical location in a typical commercial and/or hospital environment

In this table, U_T is the a.c. mains voltage prior to application of the test level.

Finding Recommended Separation Distances

WARNING The device intentionally receives RF electromagnetic energy for the purpose of its operation. Therefore, other equipment may cause interference, even if that other equipment complies with CISPR emission requirements.

In the following table, P is the maximum output power rating of the transmitter in watts (W) according to the transmitter manufacturer, and d is the recommended separation distance in meters (m).

Portable and mobile RF communications equipment should be used no closer to any part of the device, including cables, than the recommended separation distance calculated from the equation appropriate for the frequency of the transmitter.

Field strengths from fixed RF transmitters, as determined by an electromagnetic site survey, should be less than the compliance level in each frequency range.

Interference may occur in the vicinity of equipment marked with this symbol:



Table 2

Conducted RF Immunity Test EN/IEC 61000-4-6				
IEC 60601-1-2 Test Level over 150 kHz to 80 MHz	Frequency Range (where Immunity Level is below IEC 60601-1-2 Test Level at certain frequencies)	Known RF Sources within Frequency Range	Worst Case Immunity Level within Frequency Range	Electromagnetic Environment Guidance: Recommended Separation Distance (d) (in Meters, at Frequency Range Tested) for Ultrasound and ECG Measurements
<p>Note: The device meets the compliance level of $3.0 V_{RMS}$ according to IEC 60601-1-2 for most of the specified test frequency range. However, within the frequency ranges specified in this table, there are some frequencies at which the immunity level is below the IEC 60601-1-2 test level. Within each frequency range, the worst case immunity level is given. Over the frequency range 150 kHz to 80 MHz, the recommended separation distance in meters (d) is found by the following equation:</p>				
$d = \left(\frac{3,5}{V1}\right)\sqrt{P}$				
<p style="text-align: center;">For a compliance level of $3.0 V_{RMS}$:</p>				
$d = 1,2\sqrt{P}$				
3.0 V	0.5 MHz - 1.6 MHz	Medium Wave (AM) radio stations	0.1 V @ 1.003 MHz	$d = 35,0\sqrt{P}$
<p>Key:</p> <p>d = Recommended separation distance in meters (m)</p> <p>P = maximum output power rating of the transmitter in watts (W) according to the transmitter manufacturer</p> <p>$V1$ = Tested compliance level (in Volts) for the Conducted RF Immunity test IEC 61000-4-6</p>				

Table 3

Radiated RF Immunity Test EN/IEC 61000-4-3				
IEC 60601-1-2 Test Level over 80 MHz to 2.5 GHz	Frequency Range (where Immunity Level is below IEC 60601-1-2 Test Level at certain frequencies)	Known RF Sources within Frequency Range	Worst Case Immunity Level within Frequency Range	Electromagnetic Environment Guidance: Recommended Separation Distance (d) (in Meters, at Frequency Range Tested) for Ultrasound and ECG Measurements
<p>Note: The device meets the compliance level of 3.0 V/m according to IEC 60601-1-2 for most of the specified test frequency range. However, within the frequency ranges specified in this table, there are some frequencies at which the immunity level is below the IEC 60601-1-2 test level. Within each frequency range, the worst case immunity level is given.</p> <p>Over the frequency range 800 MHz to 2.5 GHz, the recommended separation distance in meters (d) is found by the following equation:</p> $d = \left(\frac{3,0}{E1}\right)\sqrt{P} \quad \text{For a compliance level of 3.0 V/m:} \quad d = 1,2\sqrt{P}$ <p>Over the frequency range 800 MHz to 2.5 GHz, the recommended separation distance in meters (d) is found by the following equation:</p> $d = \left(\frac{7,0}{E1}\right)\sqrt{P} \quad \text{For a compliance level of 3.0 V/m:} \quad d = 2,3\sqrt{P}$				
3.0 V	270 MHz - 320 MHz	Commercial radio service (for example, aircraft radio)	1.1 V @ 277.499 MHz	$d = 3,2\sqrt{P}$
3.0 V	890 MHz - 960 MHz	Commercial radio service (for example, GSM cell phones, WLAN)	0.1 V @ 925.010 MHz	$d = 70,0\sqrt{P}$
<p>Key:</p> <p>d = Recommended separation distance in meters (m)</p> <p>P = maximum output power rating of the transmitter in watts (W) according to the transmitter manufacturer</p> <p>$E1$ = Tested compliance level (in Volts/meter) for the Radiated RF Immunity test IEC 61000-4-3</p>				

Field strengths from fixed transmitters, such as base stations or radio (cellular, cordless) telephones and land mobile radios, amateur radio, AM and FM radio broadcast and TV broadcast cannot be predicted theoretically with accuracy. To assess the electromagnetic environment due to fixed RF transmitters, an electromagnetic site survey should be considered. If the measured field strength in the location in which the device is used exceeds the applicable RF compliance level above, it should be observed to verify normal operation. If abnormal performance is observed, additional measures may be necessary, such as reorienting or relocating the device.

These guidelines may not apply in all situations. Electromagnetic propagation is affected by absorption and reflection from structures, objects, and people.

If you require further information or assistance, please contact Philips Support.

Recommended Separation Distances from Portable and Mobile RF Communication Equipment

The device is intended for use in an electromagnetic environment in which radiated RF disturbances are controlled. The customer or user of the device can help prevent electromagnetic interference by maintaining a minimum distance between portable and mobile RF communications equipment and the device as recommended below, according to the maximum output power of the communications equipment.

Rated Maximum Output Power (P) of Transmitter (in Watts)	Separation Distance (d) in Meters According to Frequency of Transmitter at IEC 60601-1-2 Test Compliance Level (Figures in brackets show worst-case separation distances where tested values fall below the compliance level at certain frequencies. See previous table.)		
	150 kHz to 80 MHz	80 MHz to 800 MHz	800 MHz to 2.5 GHz
	$d = \left(\frac{3,5}{V1}\right)\sqrt{P}$	$d = \left(\frac{3,5}{E1}\right)\sqrt{P}$	$d = \left(\frac{7,0}{E1}\right)\sqrt{P}$
0.01	0.1 (3.5)	0.1 (0.3)	0.23 (7.0)
0.1	0.4 (11.1)	0.4 (1.0)	0.7 (22.1)
1	1.2 (35.0)	1.2 (3.2)	2.3 (70.0)
10	3.8 (110.0)	3.8 (10.1)	7.3 (221.4)
100	12.0 (350.0)	12.0 (32.0)	23.0 (700.0)

Removing and Replacing the Transducer Battery



Correct use



Incorrect use



Recycle according to local laws

CAUTION NEVER immerse a transducer in liquid if the battery drawer is open or has been removed. Check the condition of the drawer before refitting, and verify that it is fully closed before use.

M2720-64001 Battery Replacement Kit Contents:



x1

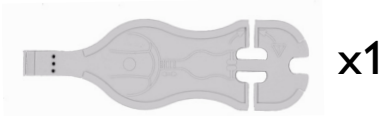

x1

Use only this tool to open drawer

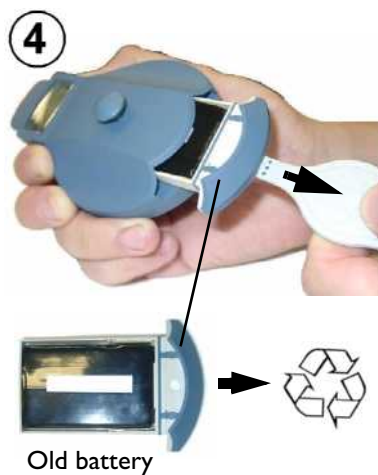
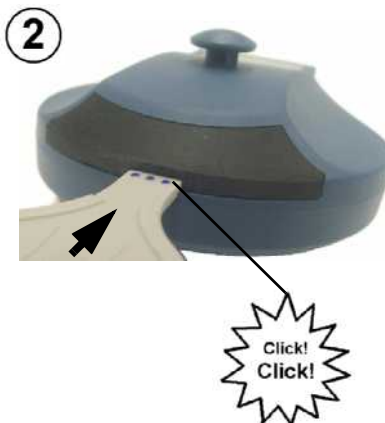
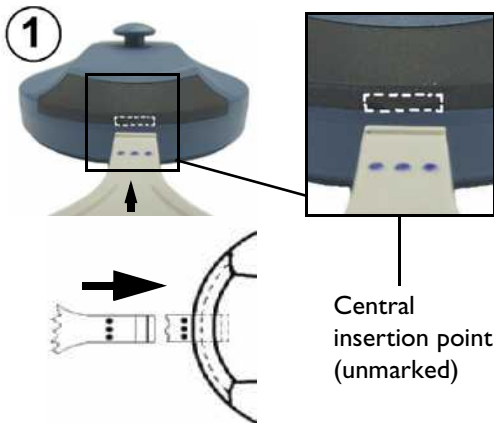

Removing and Replacing the Transducer Belt Button



Broken Knob



Dispose of item

CAUTION NEVER immerse a transducer in liquid if the belt button has been removed, or is loose, broken or damaged.

M2720-64002
Replacement Belt Button Kit
Contents:



x3

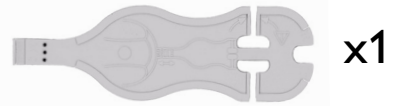

x1

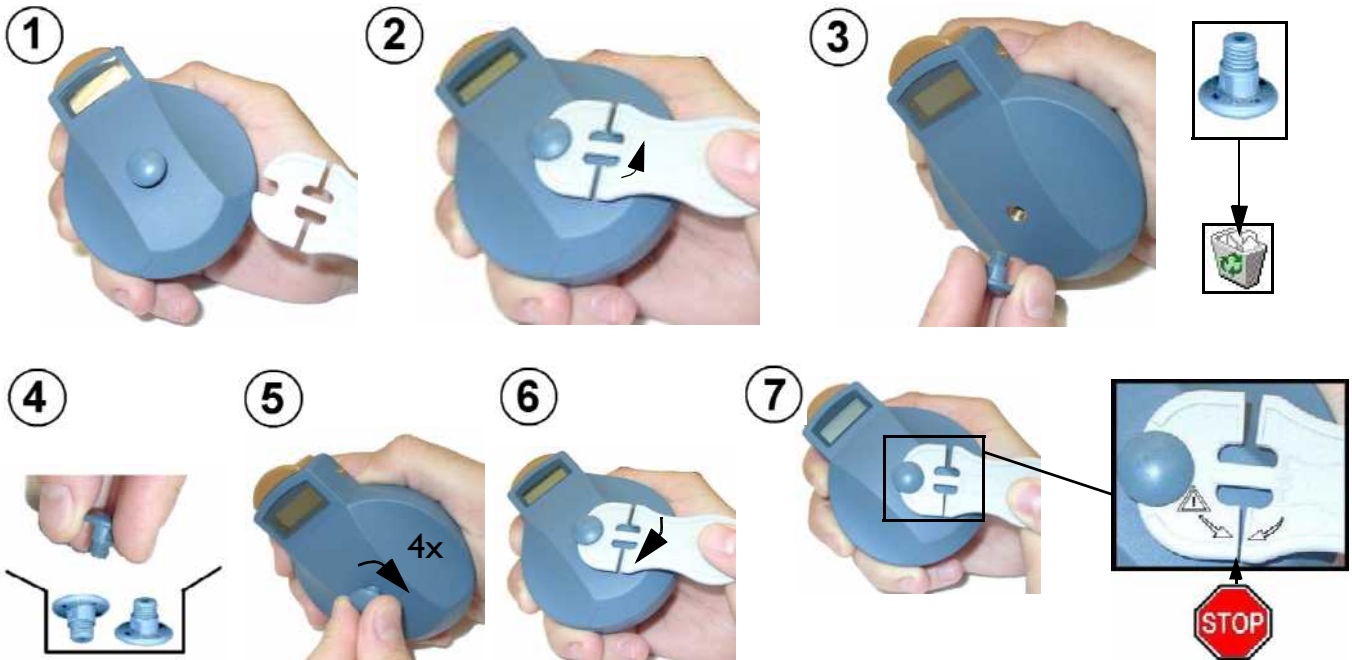

If the Button is Broken

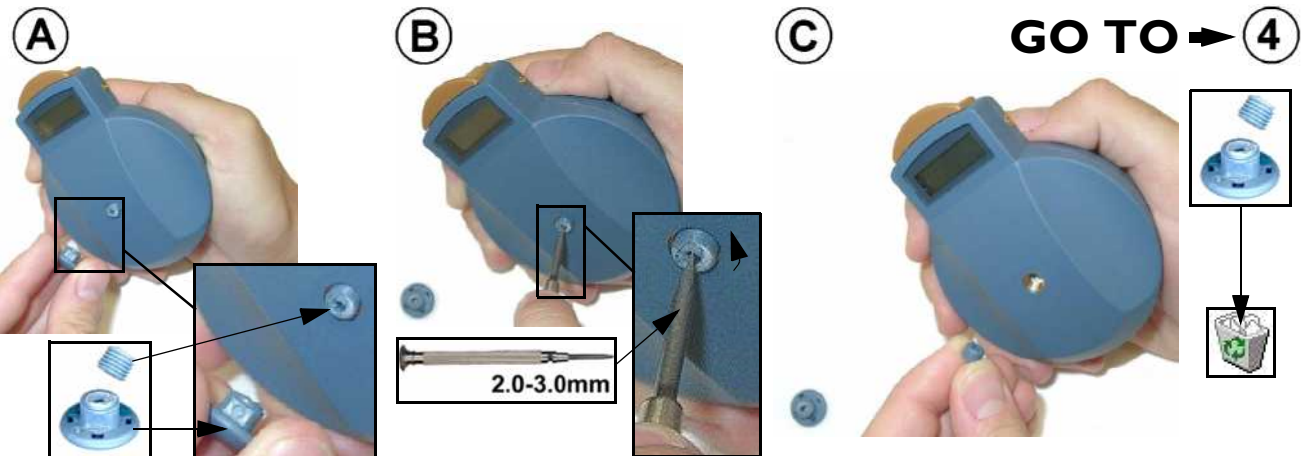

Avalon CTS Frequency Table

For multiple installations of the Avalon CTS, it is useful to keep a record of the frequency details of each system.

Base Station ID (Bed Label Number and Serial Number)	Excluded Frequencies (up to four ranges)	Base Station Fixed Frequencies		Transducer Fixed Frequencies		
		Base Frequency (F3 Setting)	Channel Spacing*	US	Toco	ECG

*Contact Philips Support before changing the channel spacing.

A

- A settings 73
- accessories 40
- action settings 77
 - clearing FIC 77
 - displaying software revision 77
- antenna
 - extension mounting kit 8
 - ISM band 40
 - mixed systems 13
 - specifications 13
 - system guidelines 12
 - system installation and site planning 12
 - WMTS band 40
- area of reach 10

B

- base station
 - hardware overview 15
 - multi-region 11
 - specifications
 - monitor interface 82
 - receiver unit 81
- battery 18
 - capacity 82
 - check 53
 - check, stages of 54
 - exchange 55
 - life 82
 - recharging time 82
 - replacement 89
 - specifications 82
 - type 82
- battery check 78
- bed label, changing appearance 74

C

- C settings 73
- cables 84
- carrier to noise ratio 60
- cart mounting 6
- cautions 3
- changing fuses 28
- cleaning (*See also Instructions for Use*) 43
- configuration
 - factors affecting 9
 - non-standard configurations 10
 - normal delivery status 10

- configuration settings 73
- conventions 3
- cordless monitoring
 - expectations 11

D

- data gathering 61
- disassembly procedures
 - MIF board removal 31
 - receiver board 33
 - tools required 26
 - top cover 26
- disassembly tools 26
- disassembly/reassembly procedures 25–37
- display window troubleshooting 72

E

- ECG transducer 18
- environment
 - operating 5
- exchange parts 39
- excluding frequencies 65

F

- F settings 73
- factory information code. *See* FIC
- fetal monitor
 - mounting system on 6
- FIC 72, 77
- fixed frequencies 65
 - enabling/disabling 74
- frequency bands
 - ISM 9
 - japan 9
 - WMTS 9

- frequency offset selection 75
- frequency options 83
- frontends

- AUX specifications 84
- ECG specifications 84
- specifications 83
- Toco specifications 83
- US specifications 83
- function buttons troubleshooting 71
- function settings 74
 - bed label appearance 74
 - fixed frequencies 74
 - frequency spacing 75

- fuses 28
 - changing 28
 - type 28

G

- general information 1

H

- hardware
 - MIF board 16
 - overview of base station 15
 - overview of transducer 17
 - transducer
 - ECG frontend 18
 - Toco frontend 18
 - US frontend 18
- HIF board 16
- human interface board. *See* HIF board

I

- installation 5
 - customer installable 2
 - special configurations 3
- instrument safety test 50
- intended readership 1
 - prerequisites 1
- interface pin connections 21
- ISM band 9, 83

J

- Japan
 - fixed frequencies 3
 - frequency bands 9
 - systems for 10

L

- latex 39

M

- M2526A 18
- magnets 72
- maintenance and safety 43–55
- maintenance, regular 51
- mechanical inspection 51
- Metron contact address 46
- MIF board
 - hardware 16
 - major blocks 16
 - overview 16

- removal 31
 - monitor
 - general description 5
 - main assemblies. *See* front and rear case assembly
 - monitor interface board. *See* MIF board
 - mounting
 - cart 6
 - GCX adapter 6
 - on fetal monitors 6
 - on flat surfaces 6
 - using Velcro tape 7
 - multi-region base station 11
- N**
-
- non-exchange parts 40
- O**
-
- operating temperatures 5
- P**
-
- patient safety 4
 - performance assurance tests 44
 - pin connections, fetal monitor interface 21
 - planning frequencies 11
 - power supply 16
 - pre-installation consideration 2
 - prerequisites for readers 1
 - protective earth test 48
- R**
-
- range definition 62
 - ready lamp 62
 - reassembly procedures
 - MIF board 36
 - receiver board 35
 - top cover replacement 27
 - receiver 16
 - board signal processing 18
 - functional description 16
 - receiver board 16
 - removal 33
 - replacing 35
 - regular maintenance 51
 - repair strategy 1, 2
 - replacing ventilation button 91
 - RF
 - interference 63
 - broadband 64
 - narrowband 63
 - RF receiver 16
 - RF/CPU hardware 17
- S**
-
- safety tests
 - instrument safety test 50
 - performance tests 47
 - power on test 47
 - S2 protective earth test 48
 - S6 enclosure leakage current test 2 49
 - visual inspection 47
 - when to perform 46
 - self test 44
 - Service Support Tool
 - excluding frequencies with 65
 - reading battery check 55
 - scanning available frequencies 64
 - setting fixed frequencies 65
 - settings
 - action 73
 - changing manually 73
 - changing with Service Tool 73
 - configuration 73
 - function 73
 - key click 73
 - slot interface, transducer 16
 - software revision, displaying 77
 - software upgrades 79
 - spare parts
 - exchange 39
 - non-exchange 40
 - specifications 81–??
 - antenna system 13
 - AUX frontend 84
 - base station 81
 - battery 82
 - ECG frontend 84
 - environmental 81
 - frontends 83
 - general 81
 - monitor interface 82
 - receiver unit 81
 - Toco frontend 83
 - transducer 82
 - US frontend 83
 - storage
 - temperatures 5
 - storage time for transducers 82
 - supplies 40
 - symbols on system 3
 - antenna input 4
 - attention 3
 - Class 2 radio eqpt. 4
 - equipotential terminal 3
 - IP68 4
 - IPX1 4
 - power/stand-by
 - indicator 3
 - switch 3
 - prot. earth terminal 4
 - service socket 4
 - type CF eqpt. 4
- T**
-
- temperatures
 - operating 5
 - storage 5
 - testing
 - after repair 2
 - ECG transducer 69
 - safety 45
 - Toco transducer 68
 - transducers 67
 - ultrasound transducer 67
 - theory of operation 15–19
 - Toco transducer
 - electrical check 68, 69
 - visual check 69
 - tools for disassembly 26
 - top cover assembly
 - removal 26
 - replacing 27
 - troubleshooting 71
 - transducer
 - battery 18
 - block diagram 17
 - communication 16
 - communication with b. station 18
 - detection 16
 - ECG 17
 - electrical check (DECG) 69
 - electrical check (MECG) 70
 - frontend hardware 18
 - hardware overview 17
 - power supply 18
 - slot interface 16
 - specifications 82
 - testing 67
 - Toco 17
 - electrical check 68
 - frontend hardware 18
 - types 17
 - US 17
 - electrical check 67
 - frontend hardware 18
 - troubleshooting 57–72
 - area of reach 62
 - checking contacts 60
 - common transducer problems 58
 - connections 60
 - cordless system 59
 - inoperative system 57
 - RF interference 63
 - RF types 60
 - system reset 57
 - top cover 71
 - display 72
 - function buttons 71
 - LEDs 72
 - magnets 72
 - using Service Tool 63



U

ultrasound transducer
 electrical check 67

upgrades
 software 79
 using Service Tool 79

V

ventilation button 91

W

warnings 3
WMTS band 9, 83